



BWT PERMAQ<sup>®</sup>  
COMPACT 111-116  
Reverse Osmosis Plant

For You and Planet Blue.

**UK**

## LIST OF CONTENTS

1.	GENERAL INFORMATION .....	4
2.	EXPLANATION OF WORDS .....	4
3.	POSITIONING OF THE PLANT .....	5
4.	WATER QUALITY .....	5
5.	WATER CONNECTIONS .....	5
5.1	Connection of inlet water (raw water).....	5
5.2	Connection of permeate (treated water) .....	5
5.3	Connection of outlet hose.....	5
5.4	Connection of overflow hose .....	5
6.	ELECTRICAL CONNECTIONS .....	5
7.	START-UP OF THE PLANT.....	6
7.1	Adjustment of outlet amount .....	6
7.2	Adjustment of recirculation amount .....	6
7.3	Dearation of transport pump .....	7
7.4	Use of by-pass .....	7
8.	AUTOMATIC FUNCTIONS.....	7
9.	MAINTENANCE AND TROUBLE-SHOOTING.....	8
9.1	Maintenance .....	8
9.2	Trouble-shooting.....	9
9.2.1	The plant capacity has dropped .....	9
9.2.2	The quality of the treated water is higher than 20 $\mu\text{S}/\text{cm}$ .....	9
9.2.3	Alarm: Low raw water pressure.....	10
9.2.4	Alarm: Transport pump .....	10
9.2.5	Indication: Level low .....	11
9.2.6	Alarm: Level high.....	11
9.2.7	The plant is not operating .....	12
9.2.8	Alarm: The transport pump stops and starts .....	13
9.2.9	Hard water is measured at the soft-water tap .....	13
9.2.10	Survey of Alarm Conditions.....	14
9.2.11	Settings.....	15
10.	TECHNICAL SPECIFICATION.....	15
10.1	Technical specifications .....	15
10.2	Technical data .....	16
11.	FUNCTIONAL DESCRIPTION .....	17
12.	CLEANING/-REPLACEMENT OF MEMBRANES .....	17
12.1	Cleaning procedure .....	17
12.2	Replacement of plant membranes.....	18
13.	ANNEX.....	19
13.1	P&I Diagram.....	20
13.2	Layout Drawings .....	21
13.3	Wiring Diagrams .....	25
13.4	Start-up Test.....	28
13.5	Operating Journal.....	29
13.6	Spare Parts List BWT PERMAQ® Compact 111-116 .....	30
13.7	Spare Parts Drawing.....	32
13.8	Declaration of Conformity .....	33

## 1. GENERAL INFORMATION

This installation and operating manual applies to BWT PERMAQ® Compact 111-116 total desalination plants.

This installation and operating manual contains important information about the correct installation and operation of the BWT PERMAQ® Compact plant.

1. Enclosed "Start-up test" (section 13.4) shall be completed and filed together with the operating journal.
2. Operating journal shall be updated as described in "Operating journal" (section 13.5).
3. Floor drain must be available in the immediate vicinity of the plant.
4. The BWT PERMAQ® Compact plant removes more than 98 % of all salts, and that is why you need to be alert to possible post-treatment with mixed bed or similar, if a better water quality is requested.
5. The authorised agent takes on full responsibility without costs for BWT who, however, grants a 12 months guarantee inclusive of replacement of defective spare parts, on condition that the parts are returned to BWT along with a specification of the fault and stating production month/year (plant no.).
6. The warranty becomes invalid, if the plant is not commissioned by an authorised BWT service technician.
7. The warranty becomes invalid, if maintenance intervals are not met.

This instruction should be read carefully before installing and starting up the plant. Correct installation and operation will also form the basis of a possible factory warranty.

Your BWT PERMAQ® Compact plant is a compact design with reservoir tank and BWT PERMAQ® Compact plant built together in order to take up a little space as possible.

The BWT PERMAQ® Compact plant with its compact and finished design is easy to install, since all installations are pre-assembled and tested in our factory.

Your BWT PERMAQ® Compact plant is equipped with casters and constructed in a stainless steel frame. That means that the plant can be placed e.g. underneath a table and then pulled out for a service check.

Your BWT PERMAQ® Compact plant is equipped with a powerful transport pump which supplies water at a pressure flow as the normal waterworks pressure/flow.

Your BWT PERMAQ® Compact plant is designed for a minimum of service and for long and unproblematic operation. However, this is on condition of correct installation and maintenance.

Always read this manual carefully before commissioning.

## 2. EXPLANATION OF WORDS

There will be a few technical explanations in this manual, which we describe below.

**Permeate:** The treated, totally desalinated water which is produced by the BWT PERMAQ® Compact plant and supplied to the reservoir tank.

**Concentrate:** Is the water that is led to outlet. This water contains the salts and minerals that have been removed from the water.

**Raw water:** Is the water which is led directly to the BWT PERMAQ® Compact plant and which must be desalinated in the BWT PERMAQ® Compact plant.

**TDS:** The amount of totally dissolved salts, measured in (mg/l)

**Conductivity:** Is the designation of salt concentration of the water, measured in (µS/cm). The lower the value, the better the water quality.

**Membranes:** Is the filter of the plant which by high pressure and flow is capable of desalinating the raw water.

**RO:** The abbreviation for Reverse Osmosis.

**Transport-pump:** is the pump which transports the treated water from the plant reservoir to the consumer.

**Level switch:** Is a switch, which gives a signal when the BWT PERMAQ® Compact plant must either be started or stopped, and it stops the transport pump in case of dry-running of the reservoir tank.

**Softening plant:** Is a pre-filter which softens the water, that means it removes hardness from the water.

### 3. POSITIONING OF THE PLANT

The plant must be placed in a non-freezing environment on an even foundation so that the water in the reservoir does not overflow when the tank is full.

the foundation must be able to stand a load of 160 kg which is the plant weight when full.

The plant is furnished with casters, so if you wish to be able to move the plant, you should keep the foundation even and solid.

The outside measures of the plant are (WxDxH): 580x630x810 mm, but when positioning the plant you should take into account that the cover shall be demounted during maintenance work. Either you must calculate with an additional 370 mm in height to be able to lift the cover, or it should be possible to roll the plant out for servicing (e.g. place it under a table or equal).

You should also make room on the back of the plant for the water installation; especially you should take into account the outlet hose from the plant.

The hose may never be bent!

Positioning of the plant must be done in a way so that the air intake on the front never gets covered.

There must also be room in front of the plant, so that it is possible to freely read the flow, and the suction of the high-pressure pump can take place without obstruction. Also it should be possible to pull out the plant in connection with maintenance.

In case of a stoppage, the reservoir may overflow. Therefore there should always be a drain in the immediate vicinity of the plant so that the overflowing water does not cause damage.

If there is no floor drain near the plant, installing the plant is at your own risk.

### 4. WATER QUALITY

The raw water, which is to be treated in the BWT PERMAQ® Compact plant, must be drinking water quality with maximum 500 mg/l TDS.

Max. raw water temperature is 25 °C. The plant is adjusted at 10 °C in our factory.

The raw water may maximum contain:

* Fe:	0.05 mg/l
* Mn:	0.02 mg/l
* Cl:	0.1 mg/l
* Turbidity:	1.0 NTU
* SDI:	3.0 %/min
* KMnO <sub>4</sub> :	10 mg/l

If there are doubts about the raw water composition, a water analysis must be made. The plant must be connected to a raw-water pressure of minimum 2 bar and maximum 7 bar. The quality of the treated water will be less than 20 µS/cm at 10 °C.

### 5. WATER CONNECTIONS

Note! All water connections must be in compliance with local regulations.

#### 5.1 Connection of inlet water (raw water)

On the inlet side you must fit a ball valve so that the water may be cut off during maintenance of the plant.

Install a ½" flexible pressure hose on the pre-filter of the plant (A-Figure 2). The opposite end shall be connected to the raw-water supply.

The best operating result is obtained by connecting to minimum ¾" raw-water pipe. That reduces the drop in pressure to the plant. With a too small raw-water connection, there will be a risk of outage on the plant due to lacking water pressure, e.g. when rinsing out the membranes at start-up of

the plant. Note! Fit the built-in flowmeter to the cabinet.

#### 5.2 Connection of permeate (treated water)

Fit the ¾" flexible pressure hose to the transport pump (B-Figure 2). The opposite end shall be connected to the consumer of the treated water or pipe connection which is led to consumer of the treated water. Note! Totally desalinated water may speed up corrosion. Therefore, always use non-corrosive piping for the treated water, e.g. stainless steel or PVC.

#### 5.3 Connection of outlet hose

Start by dismounting the "bent" blue hose which is fitted on the outlet valve (B-Figure 3).

Install the supplied 10 mm plastic hose to outlet valve (B-Figure 3). It is important that the hose is pressed all the way down. The opposite end shall be connected to outlet. The hose may not be led down into the outlet water, though, since the water may risk getting sucked back into the plant during standstill. Note! The outlet hose may never be bent or in any other way obstructed, as this would damage the plant membrane.

#### 5.4 Connection of overflow hose

On the back of the plant, on the overflow nozzle (C-Figure 2), you shall connect a ½" plastic hose to the floor drain or another subjacent drain. This overflow is a safety overflow in case an fault occurs on the level switch of the plant and the reservoir tank as a consequence gets filled to overflowing.

### 6. ELECTRICAL CONNECTIONS

Note! The electrical connections must be made in compliance with local regulations.

The electrical connection to the BWT PERMAQ® Compact plant must be as follows:

- \*Voltage: 230 Volt-50 Hz
- \*Fuse: 10 Amp
- \*Max. power consumption: 1.5 kW

Colour code of power cable:

- Blue wire: N
- Brown wire: L
- Yellow/green wire: PE

If for some reason you need to change the factory-mounted power cable, please cf. Annex – 13.3 Wiring Diagrams.

All internal connections in the plant like e.g. pump control and level control are pre-assembled in our factory. This means that only the supplied wire which is connected to the control box (C-Figure 3) must be connected to a power plug or hard wired.

## 7. START-UP OF THE PLANT

Read section below carefully before starting up the plant.

- Check prior to start-up that all water and electrical connections are made as described in previous sections and in compliance with local regulations.
- Open the raw-water supply.
- Check that all water connections are tight.
- Pull the permeate hose (A-Figure 3) out of the reservoir tank and lead it away from the tank to a drain.
- Open the outlet valve (B-Figure 3) complete and close the recirculation valve (D-Figure 3).
- Now switch on the 230 Volt 50 Hz power supply. Also switch on the main switch located on the control box (C-Figure 3).
- The plant is now operating.
- Now the plant shall operate and flush to outlet for 20-30 minutes before adjusting the outlet valve once more.

- When the flushing is finished, adjust the outlet valve (B-Figure 3) and recirculation valve again.

REMEMBER! Under all given conditions, the following must be complied with:

- Permeate amount: Max plant capacity (l/h), 10-25 °C
  - Operating pressure: 13.5-14.5 bar
  - Maximum pressure: 15 bar
- Permeate amount and max. pressure may never exceed above-mentioned as it would cause damage to the plant membrane.

### 7.1 Adjustment of outlet amount

*Important! Read the entire section 7.1 and 7.2 before adjustment is commenced.*

Outlet amount must be adjusted, and the suitable outlet amount on your plant depends on the raw-water quality. A too high water recovery will damage the plant membranes. On condition that the raw water complies with the quality requirements, the plant can operate with a recovery rate of 40 %. With softened feed water, you may obtain a recovery of 70-80 % dependent on the amount of organic material in the water.

Finally, the plant recovery affects the conductivity of the permeate. That means that if a retention greater than 98 % is requested, the plant recovery can be adjusted at a lower level. Please note that the plant retention rate of 98 % applies by 75 % recovery. Contact BWT or the supplier of your plant to decide which outlet amount is suitable for your water.

An easy way of checking the outlet amount of the plant is:

$$\text{Outlet amount (l/h)} = \frac{100 \times \text{permeate capacity (l/h)}}{\text{recovery}(\%)} - \text{permeate capacity (l/h)}$$

Ex.: BWT PERMAQ® Compact 113 with 40% recovery

$$\text{Outlet amount} = \frac{100 \times 150}{40} - 150 = 225 \text{ l/h}$$

Type of plant	Permeate Capacity (l/h)	Outlet amount (l/h)		
		Ground water (40% recovery)	Surface water (50% recovery)	Softened water (75% recovery)
111	50	75	50	17
112	100	150	100	33
113	150	225	150	50
114	200	300	200	67
115	250	375	250	83
116	300	450	300	100

When the requested amount of outlet water has been obtained, tighten the lock nuts on the outlet valve (B-Figure 3) so that it is locked. It is important to check the outlet amount after the lock nuts have been tightened to make sure that the valve has not moved. Both lock nuts must be tightened.

Important! The outlet valve must be locked on the prescribed outlet amounts. If the needle valve is closed so that the outlet amount is reduced, then the plant membranes will become damaged.

### 7.2 Adjustment of recirculation amount

Then the recirculation amount (D-Figure 3) must be adjusted by loosening lock nut on the recirculation valve. Adjust the permeate amount at maximum 50-300 l/h for BWT PERMAQ® Compact 111-116 respectively, at a temp. of 10-25°C.

If the temp. is below 10 °C, the capacity will be 3 % below normal capacity for every degree under 10 °C.

If e.g. the raw-water temp. is 8 °C, for an BWT PERMAQ® Compact - 114 it means that the permeate

capacity is 6 % below the normal 200 l/h, i.e. 188 l/h. At the same time make sure that the pressure on the manometer (E-Figure 3) does not exceed 12 bar + inlet pressure from the water supply, however maximum 15 bar.

The normal pressure indicated on the manometer in order to obtain normal permeate capacity will be approx. 13.5-14.5 bar.

When the requested pressure and permeate capacities have been obtained, check again if the outlet amount has been adjusted correctly.

(We recommend that you loosen both lock nuts while the valves are fine-adjusted).

When both valves have been adjusted, they shall be locked with the lock nuts. Please take care not to move the valve when you tighten the lock nut.

NB! When the valves have been locked, the plant shall be started and stopped 4-5 times, and then the flow shall be checked again; the valves are re-adjusted if necessary.

Now check that the quality of the treated water on the permeate hose (A-Figure 3); the conductivity shall be below 20  $\mu\text{S}/\text{cm}$  (conductivity meter is available as accessory). If the water quality is below 20  $\mu\text{S}/\text{cm}$  it is OK and the hose can be led back to the hole in the reservoir tank.

The 100 litre reservoir tank now will be filled up with treated water <20  $\mu\text{S}/\text{cm}$ .

Write the operating data in the enclosed operating journal (see section – 13.5 Operating journal).

### 7.3 Dearation of transport pump

The transport pump (G-Figure 3) is controlled by a pressure switch and hydrophore is preset to 2.7 bar from our factory, so they do not have to be adjusted

Note! The transport pump (G-Figure 3) will not start until the reservoir tank has been completely full. Wait for the reservoir tank to fill up completely (approx. 20 minutes). Check that the level switch (H-Figure 3) automatically stops the plant when the reservoir tank is full.

NB: Do not touch the level switch. Create a large consumption of treated water to get the air out of the pump.

Check that the transport pump (G-Figure 3) starts up automatically. Check that the pump supplies water and pressure.

When you have checked the transport pump and found it to be in order, close for consumption of treated water.

Wait for the transport pump to stop automatically.

Note! The transport pump does not stop until 20/30 seconds after the consumption has ceased due to the built-in delay in the control box.

Once again create a consumption of treated water and this time let the transport pump (G-Figure 3) empty approx. 25 litres of the reservoir tank content. Check if the plant starts up automatically and produces treated water. This can be read on the flow meter (F-Figure 3). The plant is now commissioned and ready for use.

### 7.4 Use of by-pass

Furthermore the plant is furnished with a manual by-pass for raw water, i.e. if the plant for some reason experiences disturbances, this valve can be opened and you will have raw water on the outlet for consumption.

IMPORTANT! When the plant is restarted, you must remember to close the by-pass valve again, otherwise you will get a mixture of permeate and raw water on the outlet.

## 8. AUTOMATIC FUNCTIONS

The BWT PERMAQ® Compact 111-116 plant is equipped with a control box with following functions integrated:

- Level switch for start/stop of high-pressure pump
- Indication of low water level and stop of transport pump
- Solenoid valve controls raw water inlet
- Pressure switch for start/stop transport pump (Stop 4.0 bar, Start 3.0 bar)
- Alarm will go off when raw water pressure drops below 0.5 bar for more than 2 min
- Alarm will go off if transport pump has been running for more than 20 min
- Stop of pump is delayed by 20/30 seconds.
- Extra level switch, alarm high level (Option).
- Alarm conditions and DIP-switch - see section 9.2.10 and 9.2.11.

## 9. MAINTENANCE AND TROUBLE-SHOOTING

### 9.1 Maintenance

The BWT PERMAQ® Compact plant is produced and designed for a minimum of servicing and maintenance. However, there are certain functions which should be checked regularly. Maintenance intervals should be performed once a week – read section 13.5 Operating Journal.

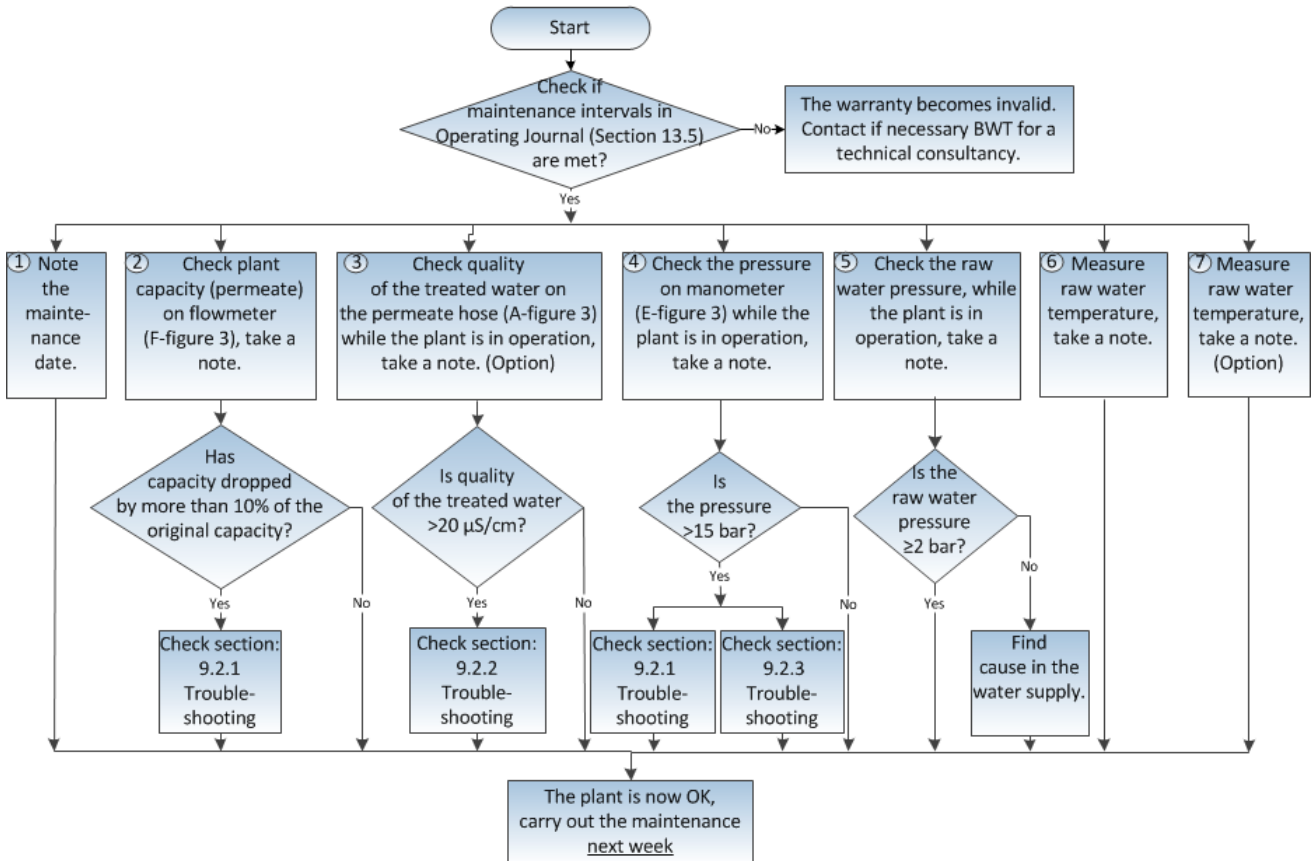



## 9.2 Trouble-shooting

This section deals with the problems that may arise on the plant.

### 9.2.1 The plant capacity has dropped

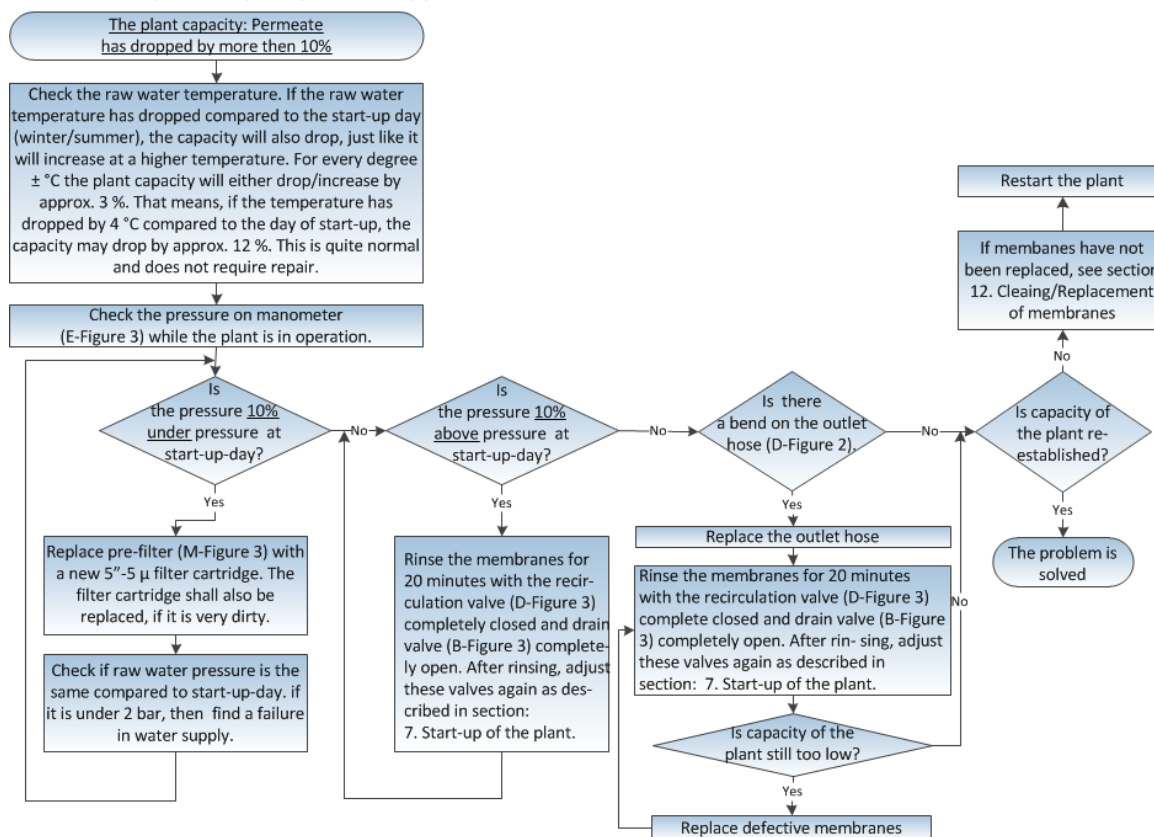

### 9.2.2 The quality of the treated water is higher than 20 μS/cm

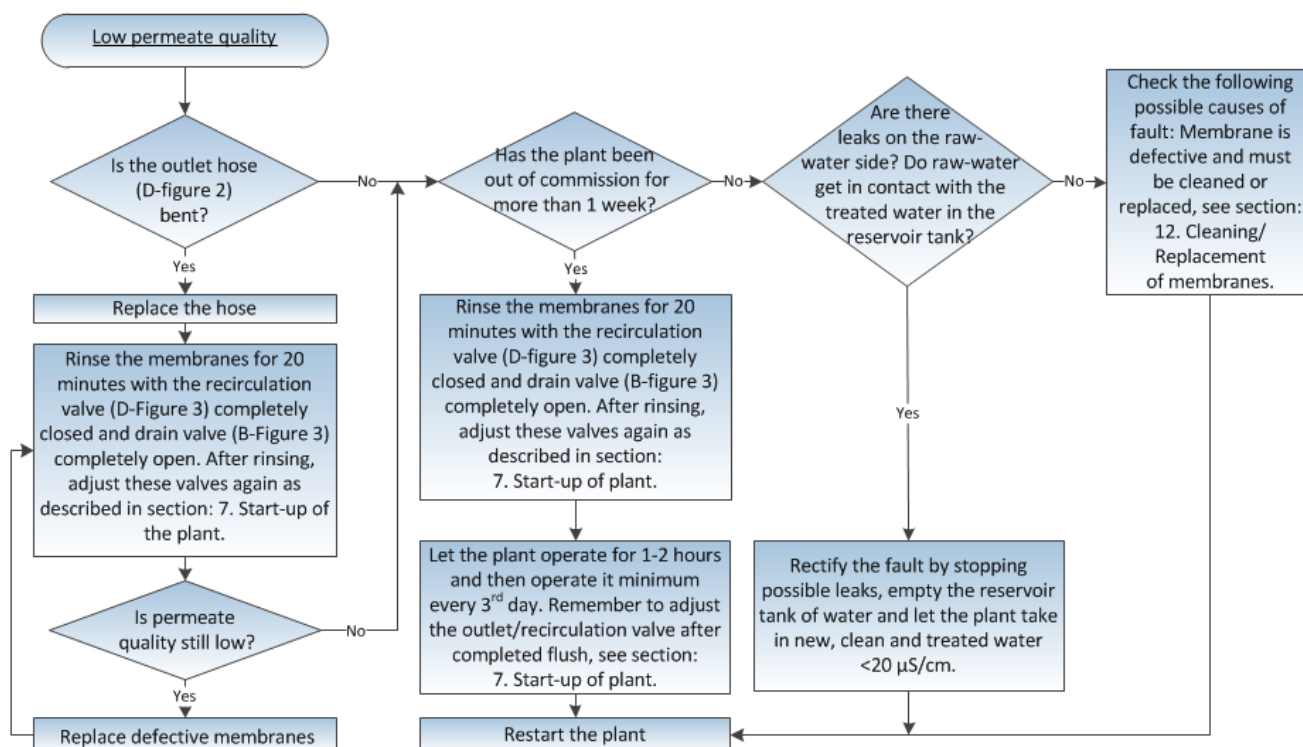

## 9.2.3 Alarm: Low raw water pressure

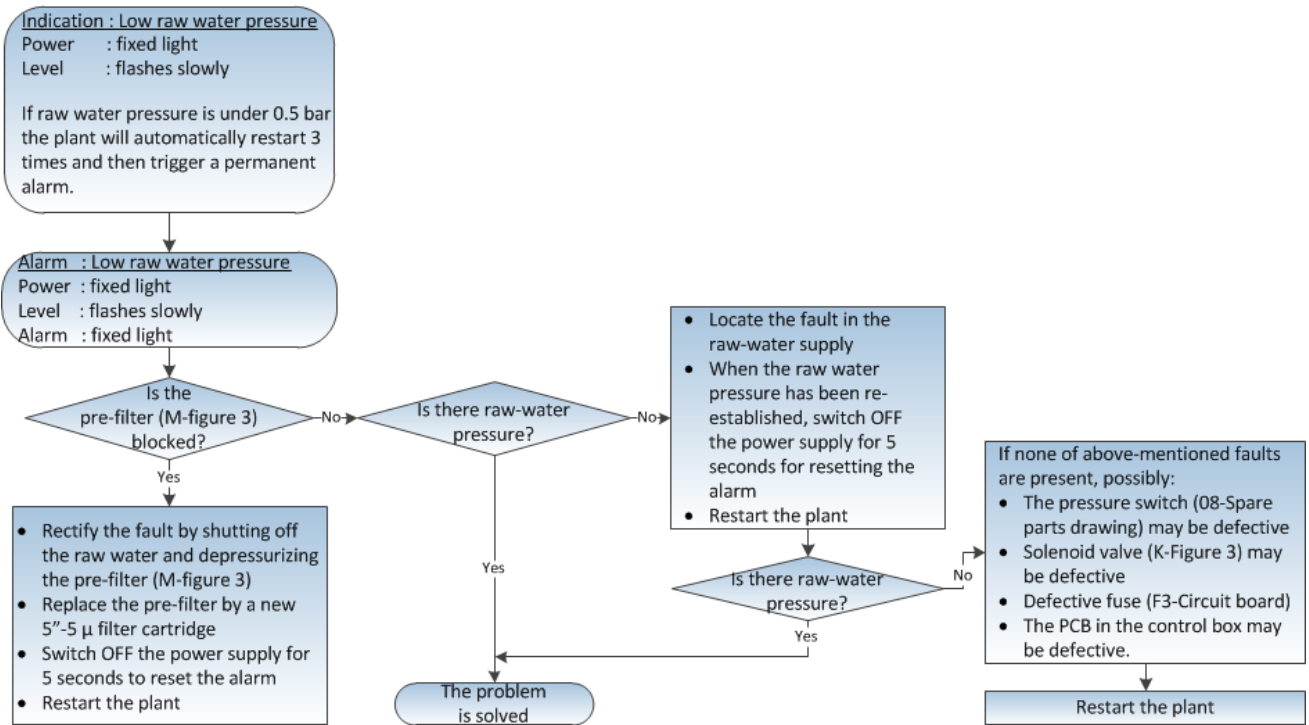

## 9.2.4 Alarm: Transport pump

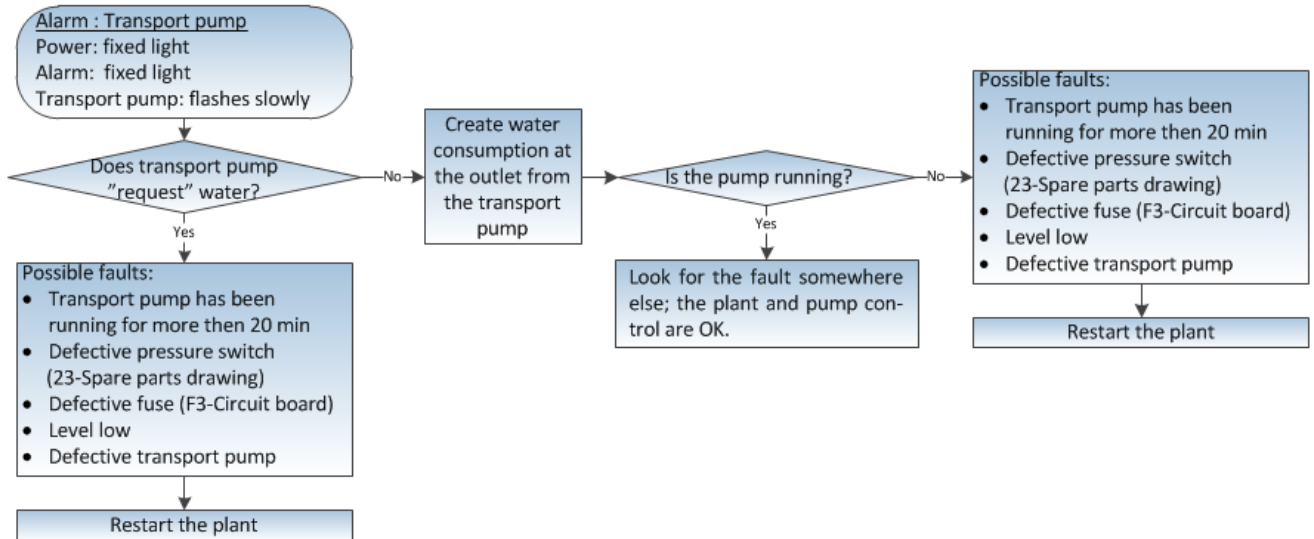

9.2.5 Indication: Level low

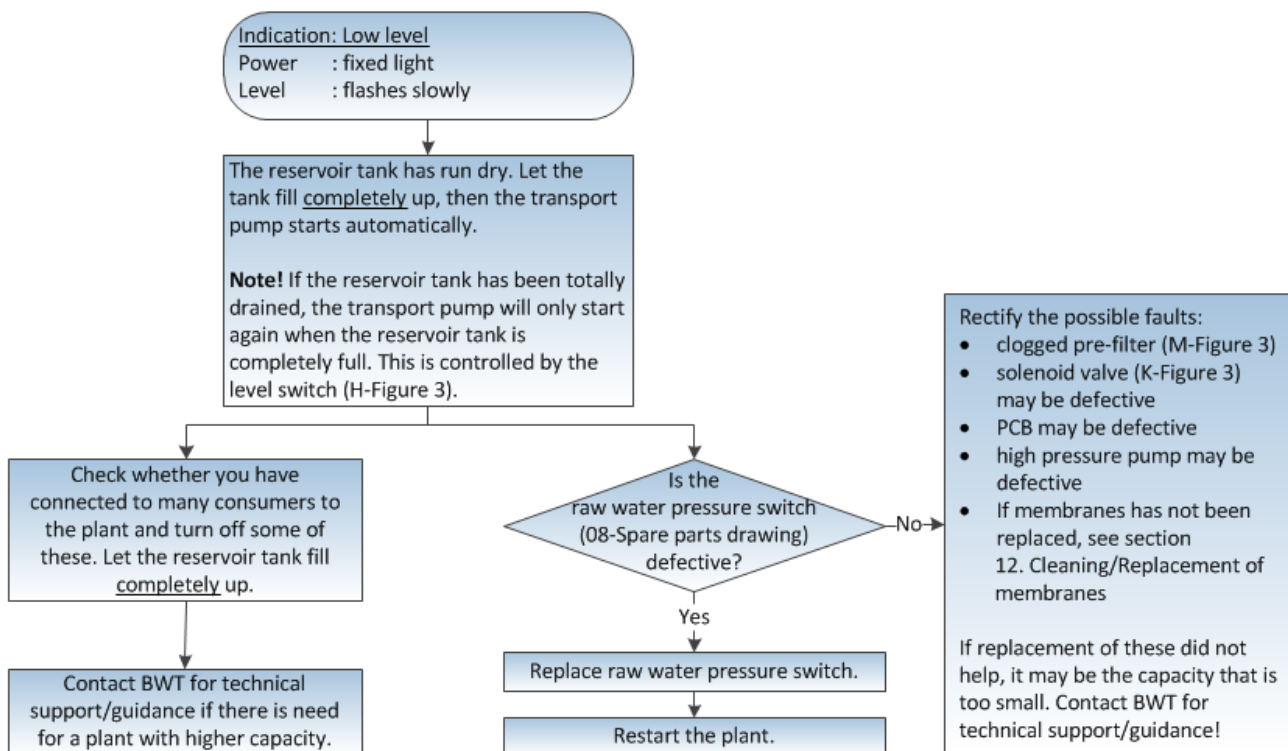

9.2.6 Alarm: Level high

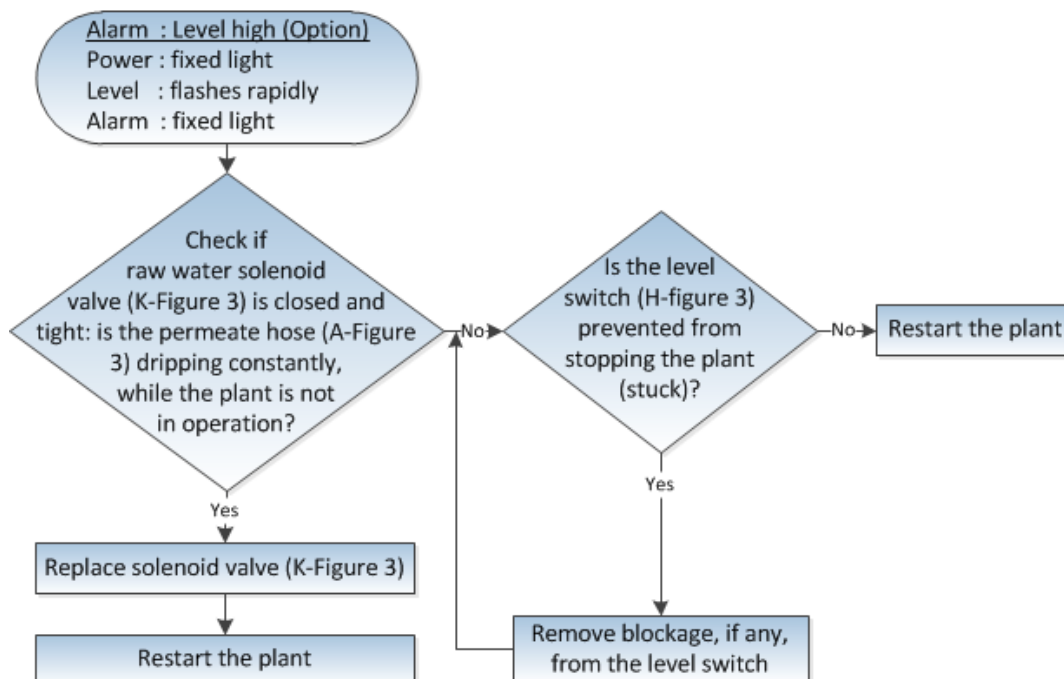

## 9.2.7 The plant is not operating

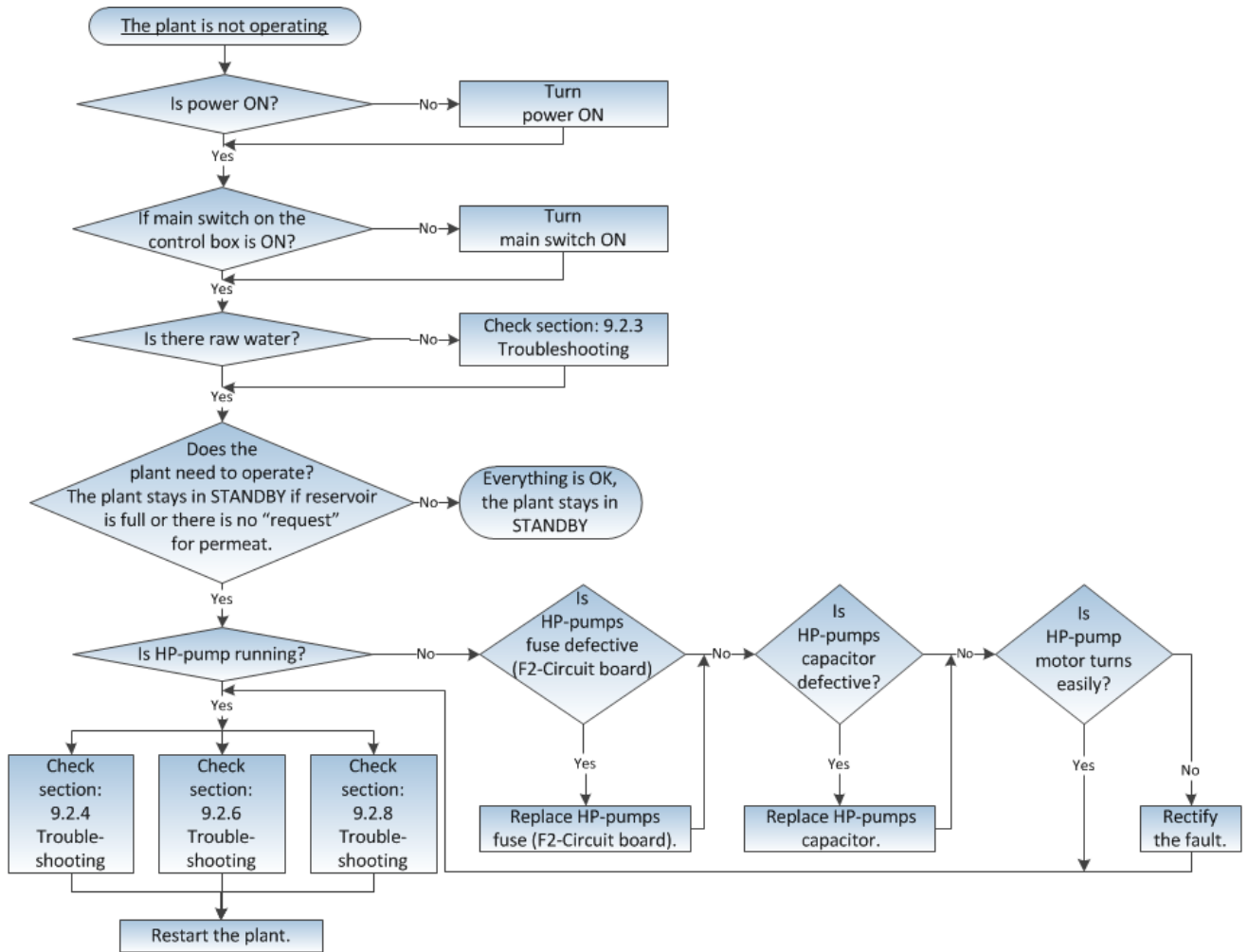

9.2.8 Alarm: The transport pump stops and starts

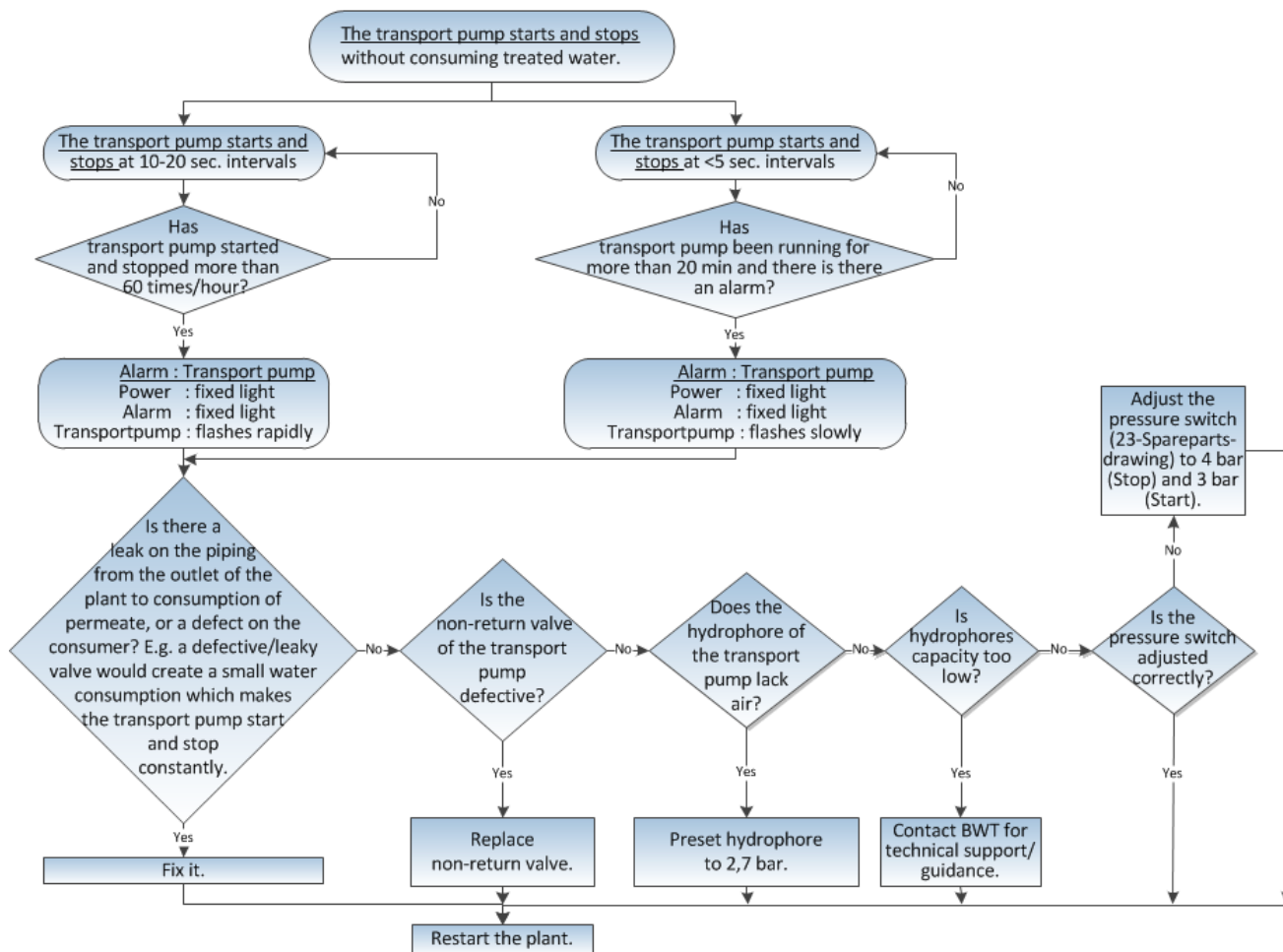

9.2.9 Hard water is measured at the soft-water tap

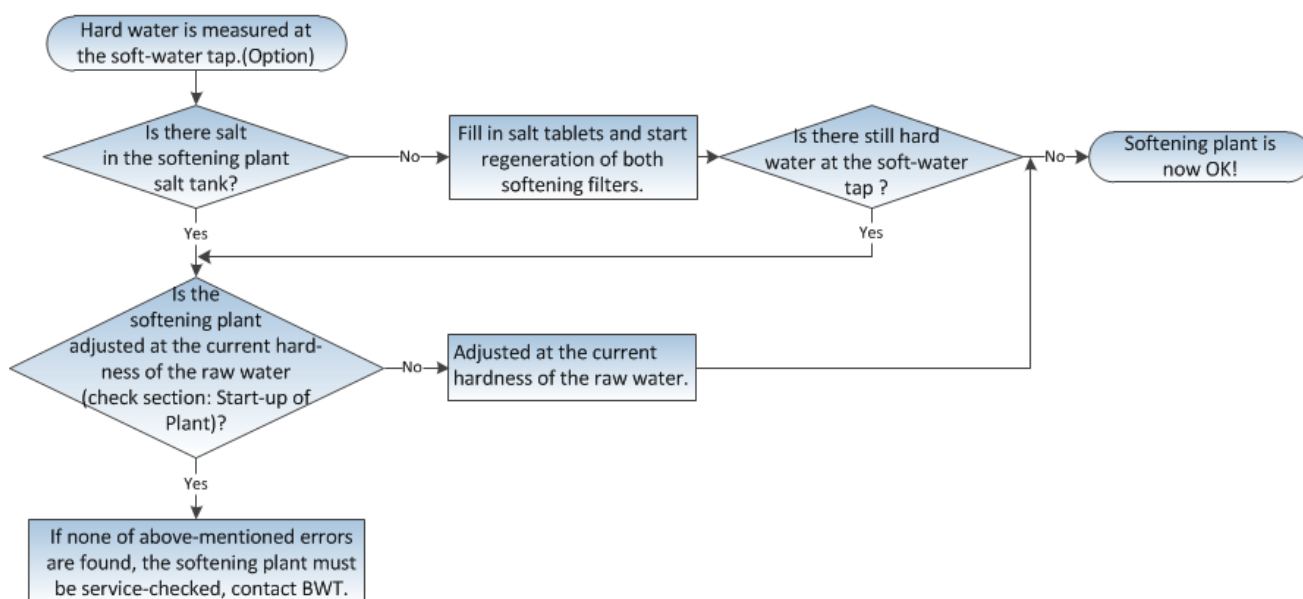

## 9.2.10 Survey of Alarm Conditions

LED function: In normal operation the LED's are lit corresponding to the components they represent.

						"Re-start ALARM" on TP-pump: (Nothing is working - permanent condition)	Section 9.2.8
						ALARM - Too high water level: (Nothing is working - permanent condition)	Section 9.2.6
						ALARM - Low water pressure and Low water level: (Nothing is working – permanent condition)	Restore raw water pressure to >0.5 bar (Section 9.2.3), then check why water level is low (Section 9.2.5)
						Too low water level (no ALARM): (TP-pump stopped, HP-pump is working)	Section 9.2.5
						"On-time ALARM" - on TP-pump: (Nothing is working – permanent condition)	Section 9.2.4
						ALARM - Too low raw water pressure: (Nothing is working - permanent condition)	Section 9.2.3
						Too low raw water pressure: (HP-pump stopped - TP-pump is working)	Automatic restart (3 times) if raw water pressure is <0.5 bar
						External stop - TP-pump, can be jumped at start-up: (HP-pump is working)	Remove the cause for external stop signal
						External stop - HP-pump: (TP-pump is working)	Remove the cause for external stop signal
POWER	INLET	HIGH PRESSURE PUMP (HP-pump)	TRANSPORT PUMP (TP-pump)	LEVEL	ALARM	<b>Description of alarm- and fault conditions</b>	<b>Trouble-shooting/ comments</b>

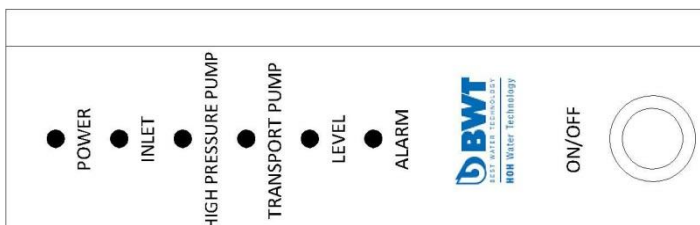

LED's are lit	LED's flashes slowly (1/2 Hz)	LED's flashes rapidly (5 Hz)

The plant emits beep tone at Alarm condition (Nothing is working), which can only be neutralised by rectifying the fault, then switching the plant OFF for 5 seconds and switching ON again.

9.2.11 Settings

It is possible to change the various time settings for Start, Stop and Alarm, plus start-up delay of pumps.

Use of DIP-switch:

- No. 1 High-pressure pump
- No. 2 Transport pump
- No. 3 Selection of BWT PERMAQ® Compact model
- Nos. 4-6 Transport pump

FACTORY SETTING

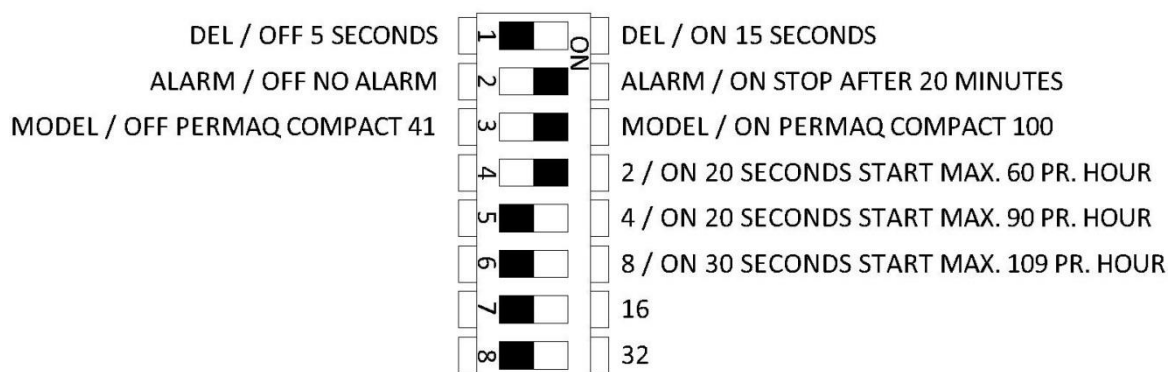

10. TECHNICAL SPECIFICATION

10.1 Technical specifications

<b>BWT PERMAQ® Compact 111-116</b>		
Tag number	Designation	Type/data
P1	High-pressure pump	14 bar, 1x230V, 0.64kW
P2	Transport pump	1x230V, 0.85 kW
FI 1	Flow meter	Ø32 PVC
PI 1	Manometer	0-40 bar, ¼"
V1	Needle valve	Brass
V2	Needle valve	Brass
Y1	Solenoid valve NC	POM
PS 1	Pressure switch NO	¼" 0.5 bar
PS 2	Pressure switch NC	¼" -0.2-8 bar
QIS 1 (Option)	Conductivity meter	½" Connection for sensor

## 10.2 Technical data

BWT PERMAQ® Compact 111-116 SERIES	111	112	113	114	115	116
Capacity, l/h*	50	100	150	200	250	300
Maximum recovery, %	40-75	40-75	40-75	40-75	40-75	40-75
Salt retention, %	>98	>98	>98	>98	>98	>98
Conductivity, µS/cm	<20	<20	<20	<20	<20	<20
Reservoir, l	100	100	100	100	100	100
Electrical connection, V	230	230	230	230	230	230
Electrical consumption, kW	1.5	1.5	1.5	1.5	1.5	1.5
Electrical frequency, Hz	50	50	50	50	50	50
Pipe inlet, Diameter, "	½"	½"	½"	½"	½"	½"
Concentrate outlet, Diameter, "	10mm Hose	10mm. Hose	10mm. Hose	10mm. Hose	10mm. Hose	10mm. Hose
Permeate outlet, Diameter, "	¾"	¾"	¾"	¾"	¾"	¾"
Height, mm	810	810	810	810	810	810
Width, mm	580	580	580	580	580	580
Depth, mm	630	630	630	630	630	630
Max. water temp., °C	25	25	25	25	25	25
Max. water press., bar	7	7	7	7	7	7
Min. water press. , bar	2	2	2	2	2	2
Weight (full), kg	150	151	152	153	154	155
No. of membranes	1	2	3	4	5	6

\* At drinking water quality 10°C, 3 bar, max. 500 mg/l total salt content.



## 11. FUNCTIONAL DESCRIPTION

The water is pressed through the RO membrane by means of a high-pressure pump. The desalinated water/permeate is then led to consumption and can e.g. be collected in a reservoir. The water containing the concentrated salts/ concentrate is led to outlet. The relation between permeate/concentrate shall be adjusted manually on the needle valve.

Under normal operating conditions the RO membranes have a long lifetime. But even with a good raw-water quality, layers of impurities will, to a certain extent, occur and there will be a slow reduction of the permeate capacity.

## 12. CLEANING/- REPLACEMENT OF MEMBRANES

*Read section 12 carefully before cleaning/replacing the membranes.*

### 12.1 Cleaning procedure

Following shall be done prior to cleaning:

Empty out approx. 50 litres of treated water from the reservoir tank.

Switch off the power supply.

Shut off the raw-water supply.

Dismount the raw-water inlet hose at the opposite end of the pre-filter (M-Figure 3).

Take out the filter cartridge located in the pre-filter housing (M-Figure 3). Fill the filter housing with raw water before remounting it. Open the outlet valve (B-Figure 3) completely and close the recirculation valve (D-Figure 3).

Lead the permeate hose (A-Figure 3) away from the reservoir tank and lead the hose up

into the bucket containing cleaning agent.

Take a plastic bucket, minimum 25 litres, or order special CIP tank for BWT PERMAQ® Compact 111-116 from BWT and fill in 25 litres of warm raw water 40°C.

Place the bucket on a somewhat higher level than the pre-filter (M-Figure 3)

Lead the raw-water connection all the way into the bucket.

Short the wires on the safety pressure switch fitted on the filter housing (M-Figure 3) by connecting the 2 wires or jump the terminals 1 and 4.

Lead the outlet hose (C-Figure 2) into the bucket with the heated water.

Start the plant by re-connecting power to the plant.

When it starts up, the plant will make some "noise" until the warm water has entered the plant.

Operate the plant in this way for 20-30 minutes, until the plant components (membranes/-pump) are heated up to approx. 40°C. Replace the water in the bucket continuously in order to keep the water at 40°C during the heating period.

When the plant components are heated up at 40 °C, you must stop the plant by switching off the power.

Re-fill water into the bucket, 40°C. We recommend using treated water for this purpose.

Mix in citric acid in the ratio 2% in 25 litres of water. I.e. ½ kg citric acid for 25 litres of water.

Re-start the plant by switching on the power.

Operate the plant for 5 min. with this solution of citric acid.

Then stop the plant for 5 min.

Operate the plant again for 5 min.

This procedure must be carried out 3 times, i.e. 3 times 5 minutes in operation and 3

times 5 minutes' break between each operating period.

If the membranes are very clogged due to belated cleaning, it is recommended to perform the cleaning procedure from the start once more with a new solution of citric acid. This extra cleaning should not be necessary if the capacity has only dropped by 10 %.

When the cleaning procedure is finished, the cleaning agent shall be disposed of in a sensible way, and the raw-water hose (A-Figure 2) shall be re-connected to the raw water.

The outlet hose (C-Figure 2) shall be led back into the drain.

Refit (possibly a new) 5"-5µ filter cartridge in the pre-filter housing (M-Figure 3) and re-connect the wire to the pressure switch on the pre-filter.

Restart the plant and flush the plant for 20-30 minutes.

When the plant has been flushed, adjust the outlet/recirculation valve (B-Figure 3) again. (see section: Start-up of Plant).

When the plant operating pressure, which can be read on the manometer (E-Figure 3) has reached 13.5-14.5 bar, check the permeate hose (A-Figure 3) to make sure the water quality is <20 µS/cm (conductivity meter can be supplied as aux. equipment). If the water quality is >20 µS/cm, then the plant must operate for 10-20 min. before making a new check-up.

Check if the plant capacity, read on the flow meter (F-Figure 3), is satisfactory.

When capacity and water quality are alright, lead the permeate hose (A-Figure 3) back into the reservoir tank.

Now the plant is ready for normal operation.

If the plant does not reach full capacity after cleaning, you must perform a new cleaning.

# UK

If, after this cleaning, the capacity of the membranes is still not satisfactory, the membranes must be discarded and new ones must be installed.

## 12.2 Replacement of plant membranes

Switch off the power.

Disassemble the plastic hoses located on the top of the membrane (J-Figure 3).

Note: how the hose is connected, since it is important that the hose be refitted in the same way!

The hoses can be pulled out by pushing the ring placed on the stainless fitting; if pushed all the way down, the hose can be pulled out.

Dismount the U-lock located at the end of the membrane pipe. (The U-lock holds the membrane endplate in place). Remove the split pin from the U-lock and pull the lock out of the pipe.

The end plate can now be pulled out of the membrane pipe by wriggling the end plate from side to side and simultaneously pulling upwards.

Now pull the membrane out of the membrane pipe. Note! at which end the large black V-cup seal on the outside of the membrane. When the new membrane is fitted, this V-cup seal must be fitted at the same end of the membrane as the old one, i.e. if the V-cup seal is at the top of the membrane pipe, the V-cup seal of the new membrane must also be installed so that the V-cup seal has to be placed at the top when the membrane is fitted inside the membrane pipe.

When the membrane has been replaced and the end plate has been refitted with the U-lock inserted, remount all hoses.

Note! When the hose must be pressed hard in to push-in fitting until it clicks .

When all connections have been refitted and end plates are securely locked with the U-lock, the plant must be restarted.

You may replace pre-filter (M-Figure 3) by new 5"-5 $\mu$  filter cartridge.

Reconnect the raw water.

Open the outlet valve (B-Figure 3) completely.

Close the recirculation valve (D-Figure 3) completely.

Dismount the permeate hose (A-Figure 3) and lead it to drain.

Reconnect the power to the plant.

The plant will now be operating. Let it flush this way for 20-30 minutes.

Then adjust the outlet valve (B-Figure 3) and the recirculation valve (D-Figure 3), see section: Start-up of plant.

Check the plant operating pressure on manometer (E-Figure 3); it should be 13.5-14.5 bar which is normal operating pressure.

Check that the water quality is <20  $\mu$ S/cm. This is checked on the permeate hose (A-Figure 3) (Conductivity meter is available as aux. equipment). Lead the hose back when the quality is satisfactory.

Check on flow meter (F-Figure 3) if the plant capacity is satisfactory. The plant is now in normal operation and ready for use.

Write in the operating journal:

1. Date of replacement of membranes
2. New capacity of plant (F-Figure 3)
3. Water quality ( $\mu$ S/cm)
4. Plant operating pressure (E-Figure 3)
5. Raw water temperature
6. Raw water pressure

13. ANNEX

13.1 P&I diagram

13.2 Layout drawings

13.3 Wiring diagrams

13.4 Start-up test

13.5 Operating journal

13.6 Spare-parts list BWT PERMAQ® Compact 111-116

13.7 Spare-parts drawing

13.8 Declaration of conformity

13.1 P&I Diagram

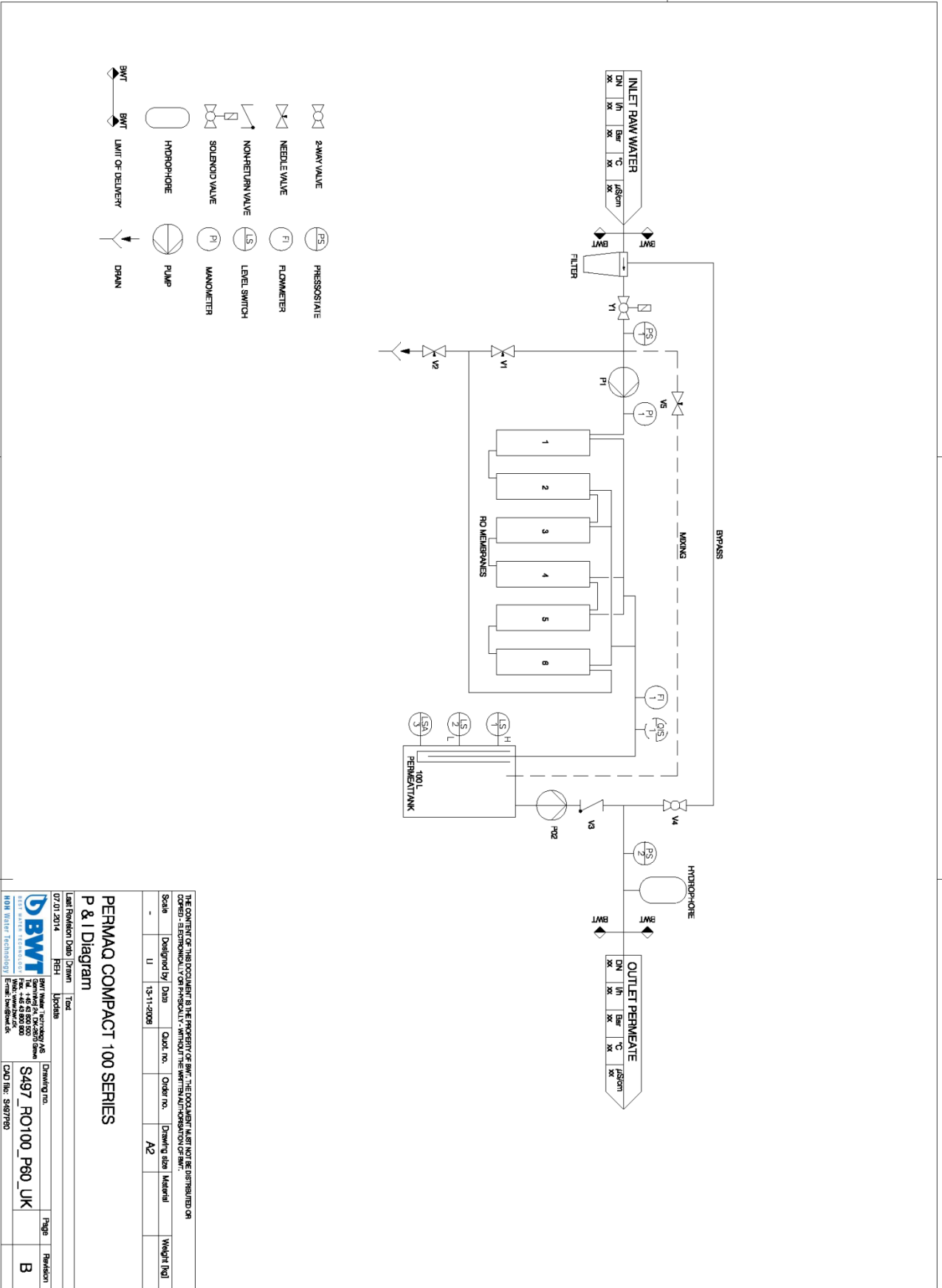

THE CONTENT OF THIS DOCUMENT IS THE PROPERTY OF BWT. THE DOCUMENT MUST NOT BE DISTRIBUTED OR  
 COPIED, REPRODUCED OR TRANSMITTED IN ANY FORM OR BY ANY MEANS WITHOUT THE BWT TECHNICAL DEPARTMENT'S PERMISSION.

Scale	Designed by	Date	Quot. no.	Order no.	Drawing size	Material	Weight [kg]
-	U	13-11-2008		A2			

07/01/2014  
 Last Revision Date  
 Drawn  
 Checked  
 Approved

		BWT Water Technology AS Svingevang 94, DK-2620 Ørum Tlf. +45 46 49 200 200 Fax +45 46 49 200 200 E-mail: bwt@bwt.dk		Drawing no. <b>S497_PO100_P80_UK</b>		Page <b>B</b>	
BWT Water Technology		CAD file: S497P80					

13.2 Layout Drawings

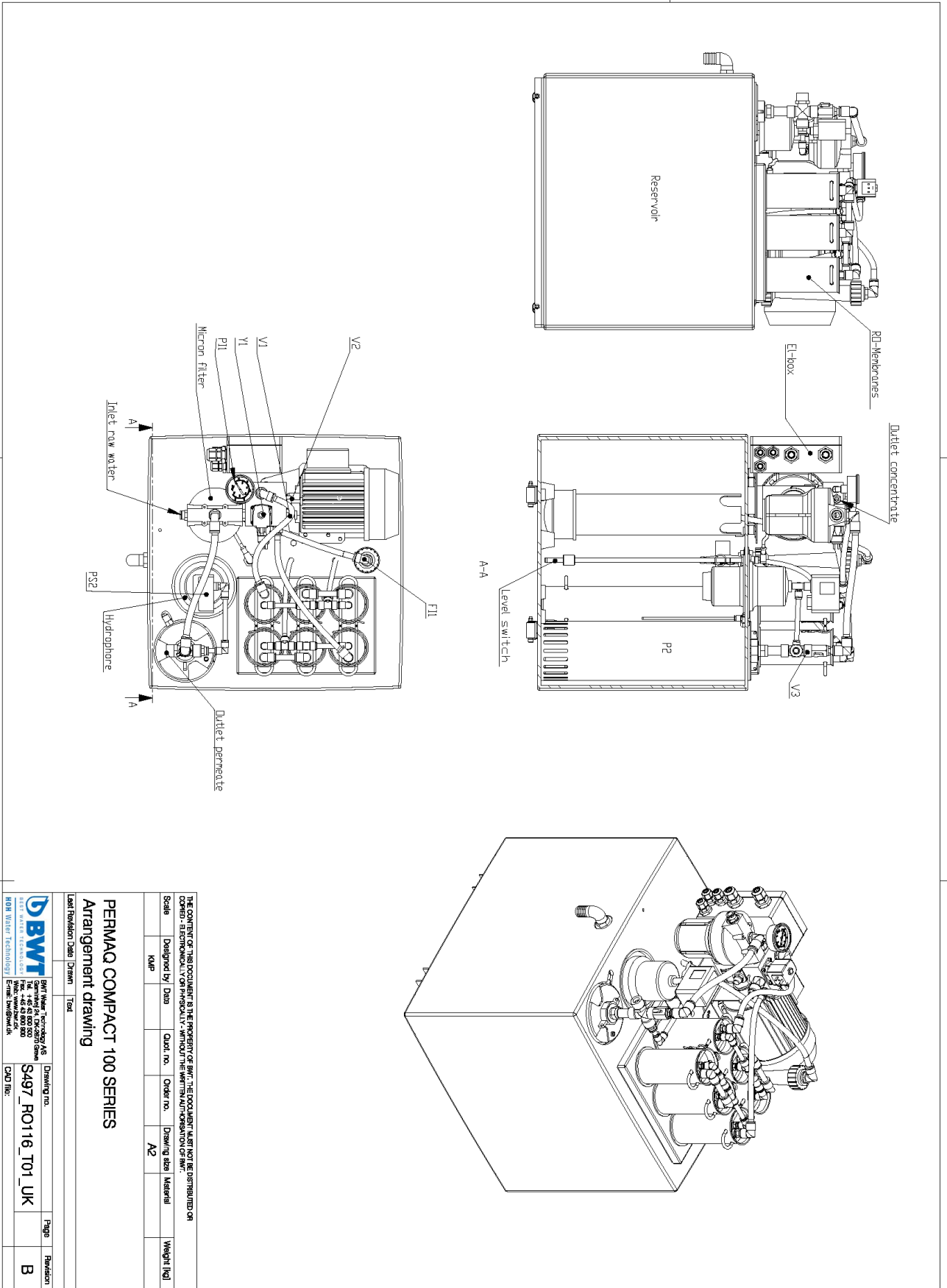

THE CONTENT OF THIS DOCUMENT IS THE PROPERTY OF BWT. THE DOCUMENT MUST NOT BE DISTRIBUTED OR COPIED - ELECTRONICALLY OR PHYSICALLY - WITHOUT THE WRITTEN AUTHORIZATION OF BWT.

Scale	Designed by	Date	Quat. no.	Order no.	Drawing size	Material	Weight (kg)
	KAP				A2		

**PERMAQ COMPACT 100 SERIES**  
Arrangement drawing

Last Revision	Date	Drawn	Total	Drawing no.	Page	Revision
				S497_R0116_T01_UK		B

**BWT** BWT Water Technology AG  
 KEES WATER TECHNOLOGY  
 Tel. +49 29 809 000  
 Fax. +49 29 809 000  
 Web: www.bwt.de  
 E-mail: bwt@bwt.de

High Water Technology  
 CMO file:

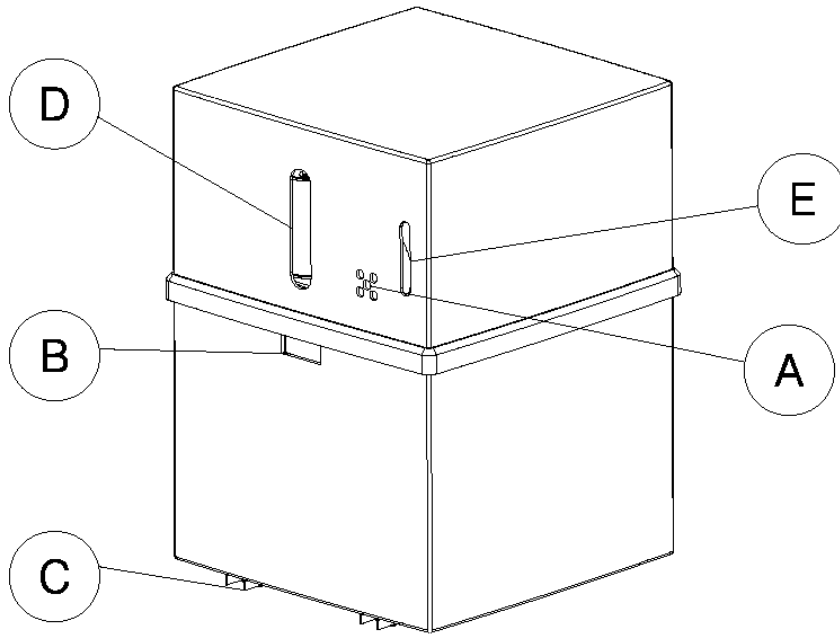

- A: Air intake for electric motor
- B: Handle for moving the plant
- C: Wheels
- D: Flowmeter
- E: Controlbox

THE CONTENT OF THIS DOCUMENT IS THE PROPERTY OF BWT. THE DOCUMENT MUST NOT BE DISTRIBUTED OR COPIED - ELECTRONICALLY OR PHYSICALLY - WITHOUT THE WRITTEN AUTHORISATION OF BWT.

Scale	Designed by	Date	Quot. no.	Order no.	Drawing size	Material	Weight [kg]
	LJ	19-01-2009			A4		

**PERMAQ COMPACT 100 SERIES**  
**FIGURE 1**  
**FRONT OF THE PLANT**

Date	Drawn	Text
20-12-2011	REH	UPDATE

 <b>BWT</b> BEST WATER TECHNOLOGY HOH Water Technology	BWT Water Technology A/S Geminivej 24, DK-2870 Greve Tel. +45 43 600 500 Fax. +45 43 600 900 Web: www.bwt.dk E-mail: bwt@bwt.dk	Drawing no.	Page	Revision
		S497_RO116_T02_UK		B
CAD file:				

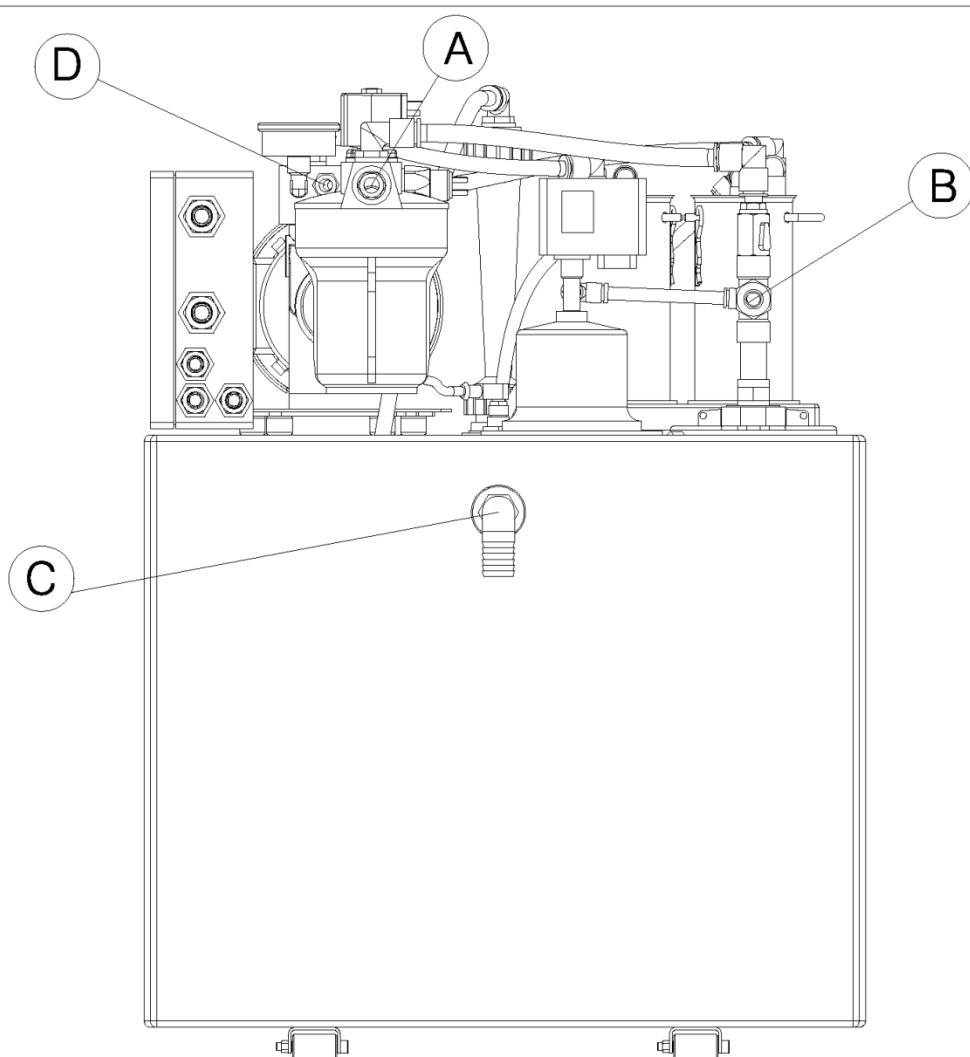

- A: Raw water inlet (1/2" pressure hose)
- B: Outlet permeate (3/4" pressure hose)
- C: Overflow brach (should be led to floor outlet)
- D: Outlet concentrate (10 mm hose)

THE CONTENT OF THIS DOCUMENT IS THE PROPERTY OF BWT. THE DOCUMENT MUST NOT BE DISTRIBUTED OR COPIED - ELECTRONICALLY OR PHYSICALLY - WITHOUT THE WRITTEN AUTHORISATION OF BWT.

Scale	Designed by	Date	Quot. no.	Order no.	Drawing size	Material	Weight [kg]
	LJ	19-01-2009			A4		

## PERMAQ COMPACT 100 SERIES FIGURE 2 BACKSIDE OF THE PLANT

Date	Drawn	Text
20-12-2011	REH	UPDATE

 <b>BWT</b> <small>BEST WATER TECHNOLOGY</small> <b>HOH Water Technology</b>	BWT Water Technology A/S Geminivej 24, DK-2670 Greve Tel. +45 43 600 500 Fax. +45 43 600 900 Web: www.bwt.dk E-mail: bwt@bwt.dk	Drawing no.	Page	Revision
		S497_RO116_T03_UK		B
		CAD file: RO116T03		

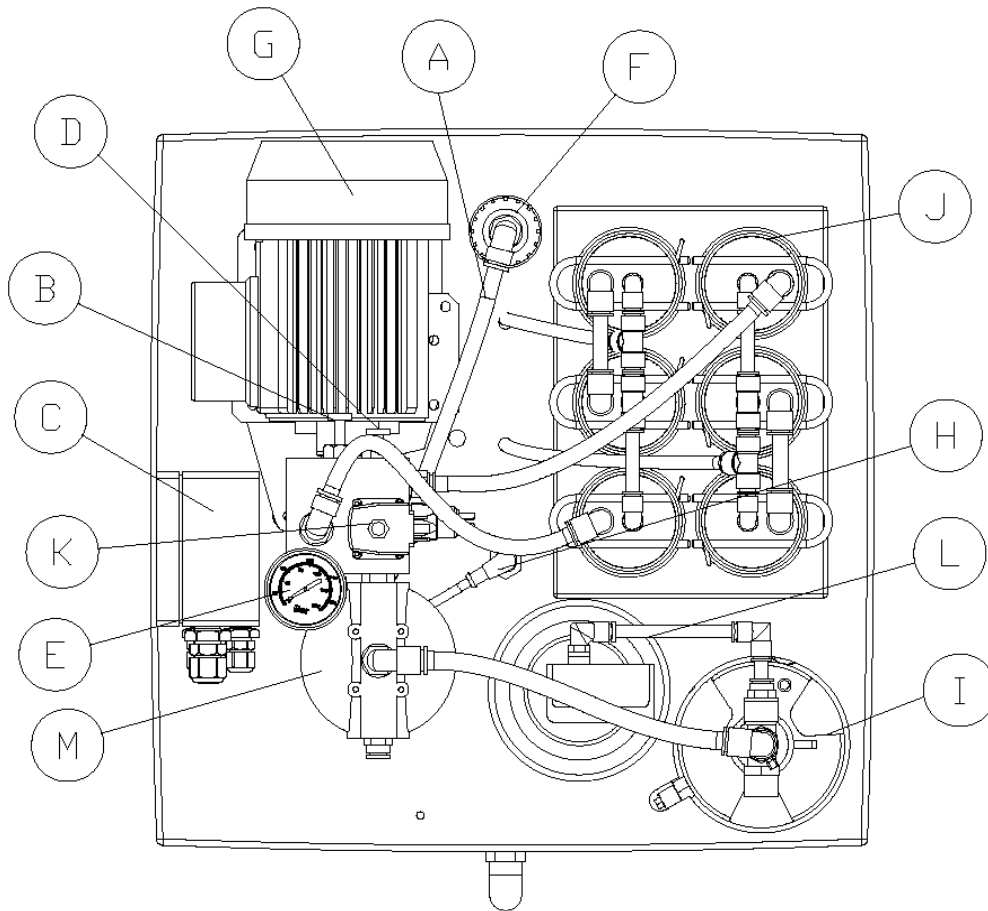



- A: Permeate hose
- B: Outlet valve
- C: Control box
- D: Recirculation valve
- E: Manometer
- F: Flowmeter
- G: High pressure pump
- H: Level switch
- I: Transport pump
- J: Membranes
- K: Solenoid valve
- L: Hydrophore
- M: Prefilter

THE CONTENT OF THIS DOCUMENT IS THE PROPERTY OF BWT. THE DOCUMENT MUST NOT BE DISTRIBUTED OR COPIED - ELECTRONICALLY OR PHYSICALLY - WITHOUT THE WRITTEN AUTHORISATION OF BWT.

Scale	Designed by	Date	Quot. no.	Order no.	Drawing size	Material	Weight [kg]
	LJ	19-01-2009			A4		

**PERMAQ COMPACT 100 SERIES**  
**FIGURE 3**  
**PLANT SEEN FROM ABOVE**

Date	Drawn	Text
20-12-2011	REH	UPDATE

 <b>BWT</b> BEST WATER TECHNOLOGY 	BWT Water Technology A/S Gerninvej 24, DK-2870 Greve Tel. +45 43 600 500 Fax. +45 43 600 900 Web: www.bwt.dk E-mail: bwt@bwt.dk	Drawing no.	Page	Revision
		S497_RO116_T04_UK		C
		CAD file: RO116T04		



13.3 Wiring Diagrams

Page . . . . .		Revision																
1	Electrical connections.....	18-11-2013 10:14																
2	Circuit board.....	18-11-2013 10:14																
<p>BWT Permaq Compact 51, 100, 270</p>		<table border="1" style="width: 100%; border-collapse: collapse;"> <tr> <td style="width: 15%; text-align: right;">Appr</td> <td style="width: 45%;">03-12-2013</td> <td style="width: 15%;"></td> <td style="width: 25%;"></td> </tr> <tr> <td style="text-align: right;">Rev</td> <td>01-09-2011</td> <td style="text-align: right;">Mik</td> <td></td> </tr> <tr> <td style="text-align: right;">Drw</td> <td>11-06-2007</td> <td style="text-align: right;">Mik</td> <td></td> </tr> <tr> <td style="text-align: right;"><del>X</del> Date</td> <td></td> <td style="text-align: right;">Ass</td> <td style="text-align: right;">Appr</td> </tr> </table>	Appr	03-12-2013			Rev	01-09-2011	Mik		Drw	11-06-2007	Mik		<del>X</del> Date		Ass	Appr
Appr	03-12-2013																	
Rev	01-09-2011	Mik																
Drw	11-06-2007	Mik																
<del>X</del> Date		Ass	Appr															
		<table border="1" style="width: 100%; border-collapse: collapse;"> <tr> <td style="width: 50%;">Main no.</td> <td style="width: 50%;">Page no.</td> </tr> <tr> <td style="text-align: center; font-size: 1.2em;">S347</td> <td style="text-align: center; font-size: 1.2em;">I 1</td> </tr> </table>	Main no.	Page no.	S347	I 1												
Main no.	Page no.																	
S347	I 1																	
 <p><b>BWT HOH A/S</b>          Geminivej 24 - Tlf. 43 600 500 - E-mail: bwt@bwt.dk          2670 Greve - Fax 43 600 900 - www.bwt.dk</p>		<table border="1" style="width: 100%; border-collapse: collapse;"> <tr> <td style="width: 100%;">Drawing no.</td> </tr> <tr> <td style="text-align: center; font-size: 1.2em;">S347E01_D</td> </tr> </table>	Drawing no.	S347E01_D														
Drawing no.																		
S347E01_D																		

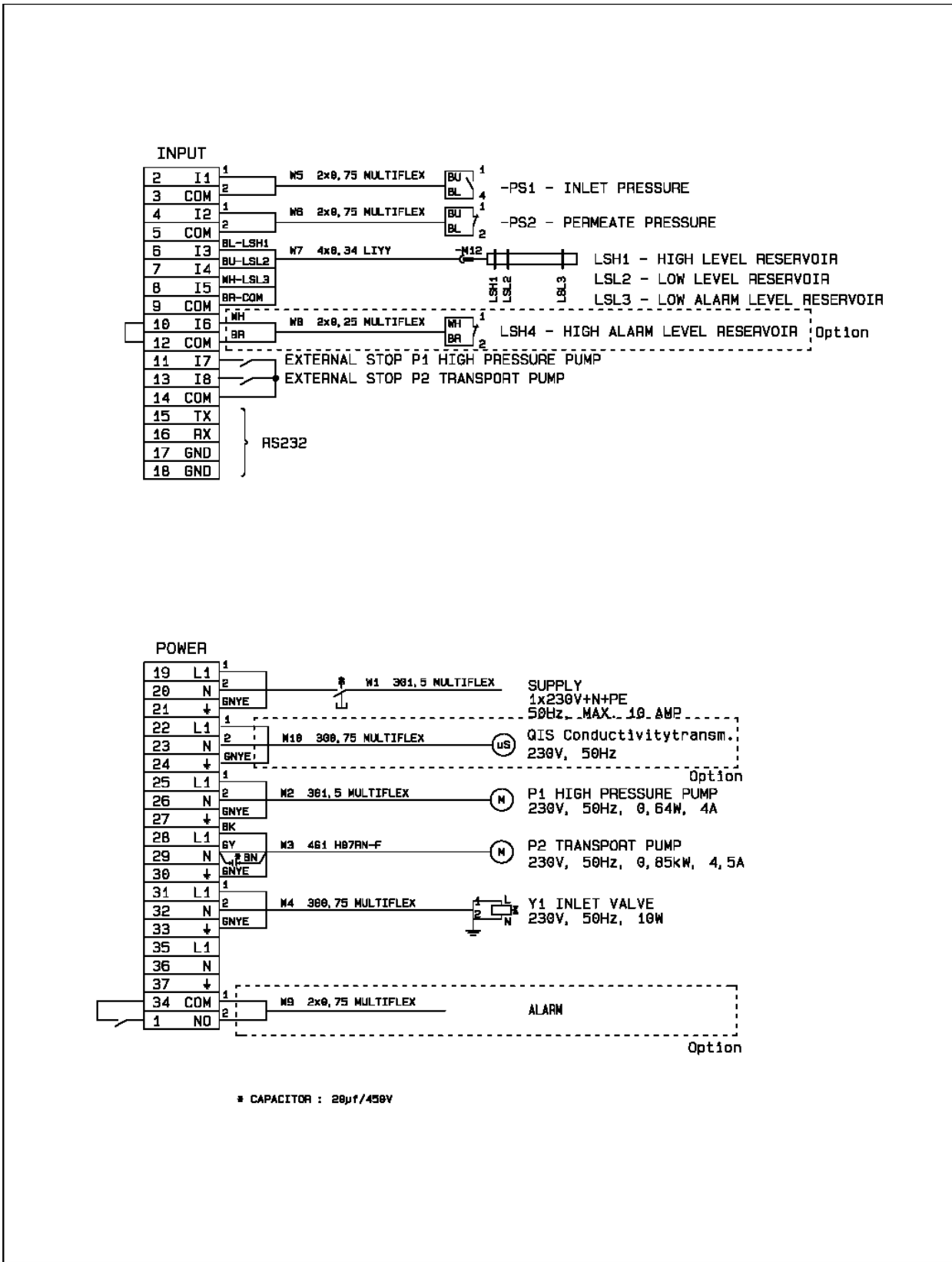

BWT Permaq Compact 51, 100, 270 Electrical connections	Appr	18-11-2013		Main no.	S347	Page no.	1
	Rev	01-09-2011	HO JRI				
	Drw	16-02-2007	HO JRI				
	Date		Ass.Appr	Draw. no.	S347E01_D		



**BWT HOH A/S**  
 Geminivej 24 - Tlf. 43 600 500 - E-mail: bwt@bwt.dk  
 2670 Greve - Fax 43 600 900 - www.bwt.dk

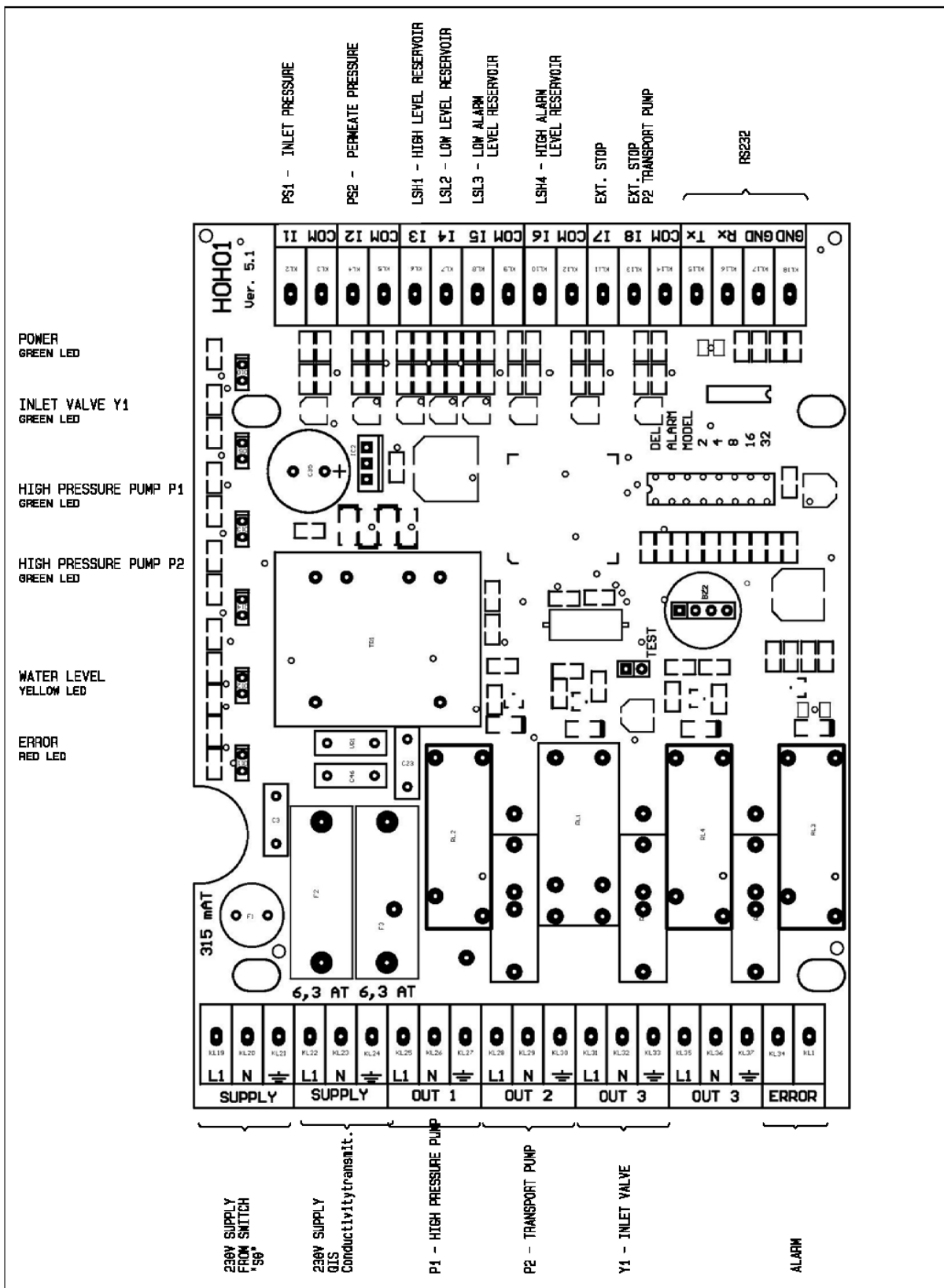

BWT Permaq Compact 51, 100, 270 Circuit board	Appr	03-12-2013		Main no.		Page no.	
	Rev	16-11-2009	HO	JRI	S347	2	
	Drw	11-06-2007	HO	JRI			
	Date				Ass.Appr		
 <b>BWT HOH A/S</b> Geminivej 24 - Tlf. 43 600 500 - E-mail: bwt@bwt.dk 2670 Greve - Fax 43 600 900 - www.bwt.dk					Draw. no. <b>S347E01_D</b>		

## 13.4 Start-up Test

<b>Start-up test</b>			
The start-up test sheet must be completed and filed together with the operating journal.			
Name of customer:		Plant number:	Work-sheet number:
<b>Test of raw water</b>			
Temperature [°C]:	Conductivity [µS/cm]:	Hardness [°dH]:	Inlet pressure [bar]:
<b>Softening unit</b> <input type="checkbox"/> YES <input type="checkbox"/> NO			
<i>If "no" skip this section</i>			
Type of plant:		Hardness [°dH] after softening:	
<i>Tick if "yes"</i>			
<input type="checkbox"/> Time-controlled	<input type="checkbox"/> Quantity-controlled	<input type="checkbox"/> Dimensioned correctly for RO	
<input type="checkbox"/> New	<input type="checkbox"/> Old	<input type="checkbox"/> Plant and salt valve set at the correct hardness	
<b>RO-plant</b>			
Type of plant:	Raw -w ater pressure [bar]:	Outlet press., high-press. pump [bar]:	Recirculation flow [l/h]:
Permeate flow [l/h]:	Concentrate flow [l/h]:	Outlet press., permeate [l/h]:	Conductivity, permeate [µS/cm]:
<input type="checkbox"/> Inlet press. switch is OK <input type="checkbox"/> Direction, high-press. pump is OK <input type="checkbox"/> Level switch, start/stop of high-press. pump is OK			
<b>Permeate tank</b>			
<input type="checkbox"/> Pre-pressured hydrophore is OK		<input type="checkbox"/> Pressure switch start/stop, transport pump is OK	
<input type="checkbox"/> Level switch have the right length for the plant		<input type="checkbox"/> Drainage protection, transport pump is OK	
<b>Status on start-up</b>			
<input type="checkbox"/> Start-up by BWT		<input type="checkbox"/> Start-up by dealer, specify dealer _____	
<b>Problems on start-up</b>			
<input type="checkbox"/> YES, there were problems at start-up		<input type="checkbox"/> NO, there were no problems at start-up	
<i>In case of problems, please fill in the problem report</i>			
<b>Problem report</b>			
Can the problem be related to the manufacturing?			
<input type="checkbox"/> YES, the problem can be related to the manufacturing		<input type="checkbox"/> NO, the problem cannot be related to the manufacturing	
Can the problem be related to the plant or the installation?			
<input type="checkbox"/> YES, the problem only concerns the plant		<input type="checkbox"/> YES, the problem only concerns the installation	
<input type="checkbox"/> YES, the problem concerns both the plant and the installation		<input type="checkbox"/> NO, the problem does not concerns the plant or the installation	
The plant - we mean only the part of the whole installation which was delivered by BWT (i.e only the plant). The installation - we mean the piping etc. leading to the plant.			
Can the problem be related to the sales department?			
<input type="checkbox"/> YES, the customer was misinformed		<input type="checkbox"/> NO, the customer had been well-informed	
Description, please describe the problem			
<b>Signature</b>			
Name/initials of technician:		Date:	Time consumption for the start-up [hours]:



## 13.6 Spare Parts List BWT PERMAQ® Compact 111-116

Position No.	BWT PERMAQ® Compact Plant	Recommended spare parts	Spare Part No.	Recommended replacement frequency
01	Cover			
02	Cabinet complete		451202018	
03	Rails on wheels		451202345	
04	Overflow nozzle		405100735	
05	Manifold block		451404690	
06	5" filter housing		321400100	
07	5"-5µ filter cartridge	2	321410000	½ year
08	Pressure switch 0.5 bar	1	452550005	
09	Solenoid valve ½"	1	200752004	
10	Manometer 0-40 bar	1	452216000	
11	Recirculation valve	1	451404680	
12	Concentration valve	1	451404681	
13	Push-in fitting, 10 mm elbow	1	454090010	3 years
13A	Push-in fitting, 12 mm elbow	1	454090012	3 years
14	Push-in fitting, 10 mm T-piece	1	454095010	3 years
15	High-pressure motor		451202495	
16	High-pressure pump		451202490	
17	Coupling for high-pressure pump	1	451202485	
18	Flowmeter, permeate		453010002	
19	Plastic fitting (flowmeter)		061282024	
20	Level switch	1	451404485	5 years
20A	Cable for level switch	1	451404450	
21	Vibration damper		451202302	5 years
22	Transport pump - 230 Volt		454100070	
23	Pressure switch, KPI 0.2-8 bar	1	451202803	
25	Hydrophore		451404571	3-5 years
27	Non-return valve		200729004	
28	Control box, complete		451404416	
28A	PCB		506708233	

Position No.	BWT PERMAQ® Compact Plant	Recommended spare parts	Spare Part No.	Recommended replacement frequency
	Membrane/pressure vessel			
30	Pressure vessel		451202068	
31	Membrane	1-4	451202038	*
32	U-lock		451202120	
33	V-Cup seal for membrane			
34	O-ring outside (large)	4-16	451202212	2 years
35	O-ring inside (small)	4-16	451404215	2 years
36	Push-in fitting, 10x1/4", base	1	454065010	3 years
36A	Push-in fitting, 12x1/4", base	1	454065012	3 years
37	End plate	2	451202117	3-5 years
	Miscellaneous			
-	10 mm plastic hose	1 m.	454001010	3 years
-	12 mm plastic hose	1 m.	454001012	3 years
-	20 µF capacitor (Transport motor)	1	750001270	
-	16 µF capacitor (High pressure motor)	1	750001860	
-	Filter wrench		321417100	
	Option			
-	Filter housing 10" complete		321401000	
-	Carbon filter 10"		321413000	½ year
-	Sensor (conductivity meter)		452536000	
-	Conductivity meter		452525000	
-	CIP tank, complete		451404573	

\* Contact your local BWT dealer for detailed information.

13.7 Spare Parts Drawing

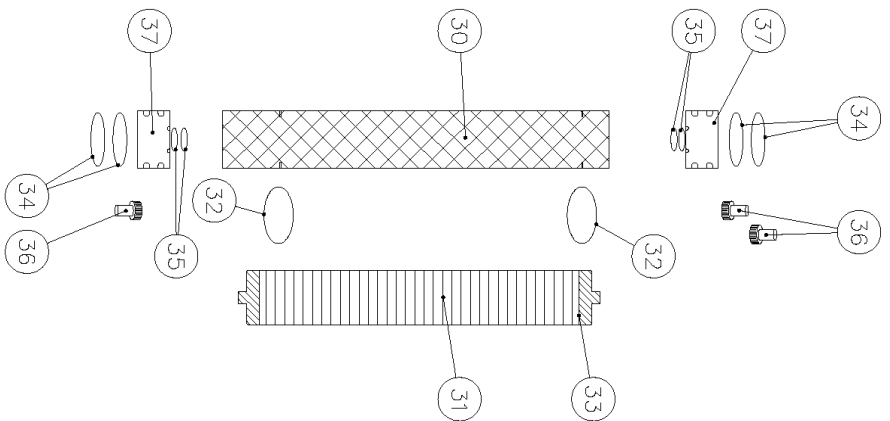
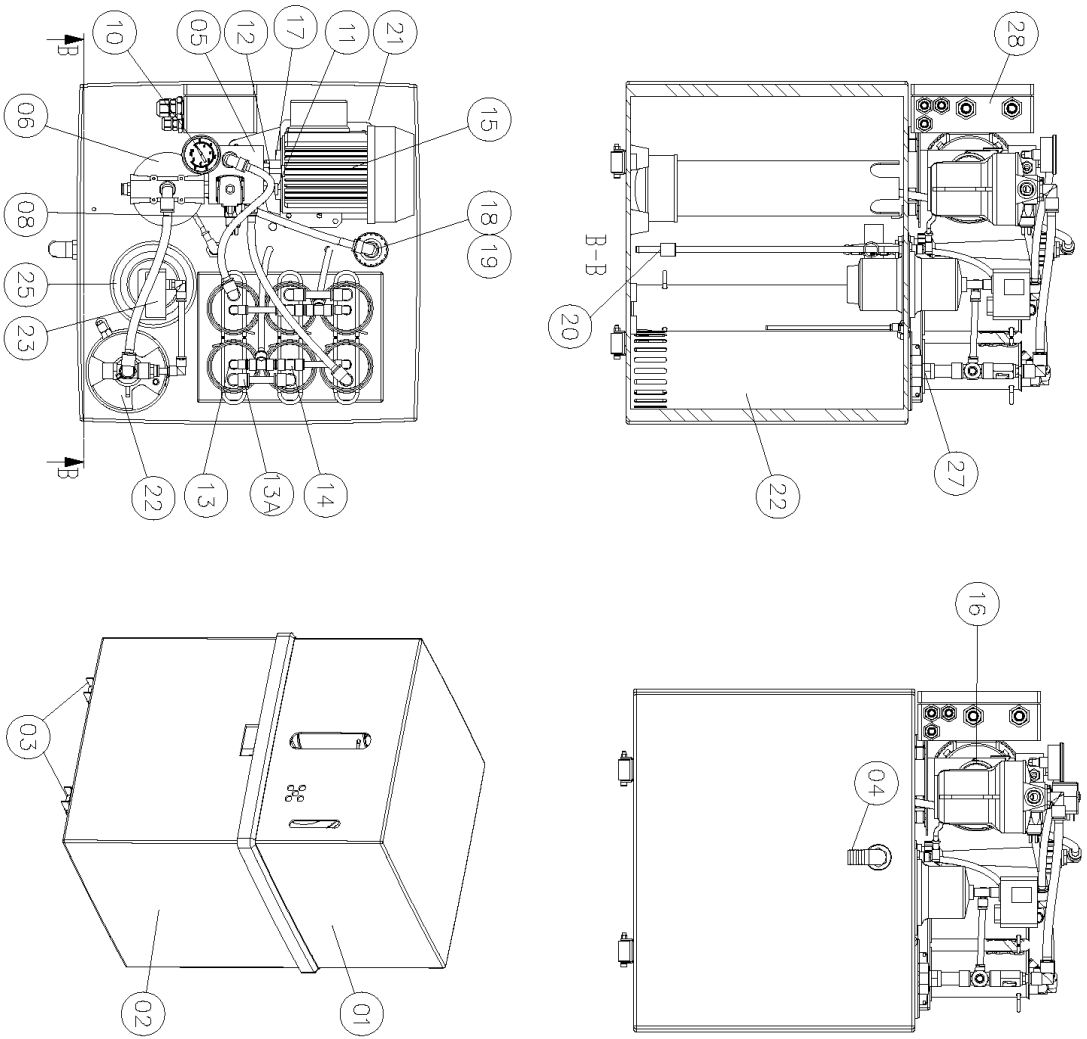

THE CONTENT OF THIS DOCUMENT IS THE PROPERTY OF BWT. THE EQUIPMENT PARTS NOT BE DISTRIBUTED OR COPIED - ELECTRONICALLY OR PHYSICALLY - WITHOUT THE WRITTEN AUTHORIZATION OF BWT.

Scale	Designed by	Date	Quot. no.	Order no.	Drawing size	Material	Weight (kg)
	U	18-01-2009		A2			

**PERMAQ COMPACT 100 SERIES**  
Spare parts drawing

Last Revision Date	Drawn	Trck	Updates	Drawing no.	Page	Revision
20-12-2011	FEB			S497_RO116_T05_UK		C

**BWT** WATER TECHNOLOGY AS  
BEST WATER TECHNOLOGY  
HORN WATER TECHNOLOGY  
BWT Water Technology AS  
Tel: +45 46 80 80 80  
Fax: +45 46 80 80 80  
Web: www.bwt.dk  
E-mail: bwt@bwt.dk

CAD file: RO116T05



## 13.8 Declaration of Conformity

EC Declaration of Conformity for Machinery  
Directive 2006/42/EC, Annex II, A  
Low Voltage Directive  
EMC Directive



**HOH Water Technology**

BWT HOH A/S

Geminivej 24 - DK-2670 Greve

tel.: +45 43 600 500 - fax: +45 43 600 900

bwt@bwt.dk - www.bwt.dk

herewith declares that:

BWT PERMAQ® Compact 111, 112, 113, 114, 115, 116

- is in conformity with the provisions of the Machinery Directive (directive 2006/42/EC)
- is in conformity with the provisions of the following other EC directives
- Low Voltage Directive (2006/95/EC)
- EMC Directive (2004/108/EC)
  
- Place: Greve, Denmark
  
- Date: 29-01-2014

---

Lars Jensen  
Head of Product Management







## For further information, please contact:

### BWT HOH A/S

Geminivej 24  
DK-2670 Greve  
Tel : +45 43 600 500  
Fax: +45 43 600 900  
E-Mail: bwt@bwt.dk

### BWT Birger Christensen AS

Røykenveien 142 A  
Postboks 136  
N-1371 Asker  
Tel : +47 67 17 70 00  
Fax: +47 67 17 70 01  
E-Mail: firmapost@hoh.no

### BWT Vattenteknik AB

Box 9226  
Kantyxegatan 25  
SE-213 76 Malmö  
Tel : +46 40 691 45 00  
Fax: +46 40 21 20 55  
E-Mail: info@vattenteknik.se

### BWT Separtec OY

PL 19 Varppeenkatu 28  
FIN-21201 Raisio  
Tel : +358 2 4367 300  
Fax: +358 2 4367 355  
E-Mail: hoh@hoh.fi

### BWT Austria GmbH

Walter-Simmer-Strabe 4  
A-5310 Mondsee  
Tel : +43 6232 5011 0  
Fax: +43 6232 4058  
E-Mail: office@bwt.at

### BWT Wassertechnik GmbH

Industriestraße 7  
D-69198 Schriesheim  
Tel : +49 6203 73 0  
Fax: +49 6203 73 102  
E-Mail: bwt@bwt.de

### Gillichemie Italiana SRL

Via Plinio 59  
I-20129 Milano  
Tel : +39 02 204 63 43  
Fax: +39 02 201 058  
E-Mail: info@cillichemie.com

### BWT France SAS

103, Rue Charles Michels  
F-93206 Saint Denis Cedex  
Tel : +33 1 4922 45 00  
Fax: +33 1 4922 45 45  
E-Mail: bwt@bwt.fr

### BWT Belgium NM.

Leuvensesteenweg 633  
B-1930 Zaventem  
Tel : +32 2 758 03 10  
Fax: +32 2 758 03 33  
E-Mail: bwt@bwt.be

### BWE Česká Republika s.r.o.

Lipovo 196 -Cestlice  
CZ-251 01 Říčany  
Tel : +42 272 680 300  
Fax: +42 272 680 299  
E-Mail: info@bwt.cz

### BWT Polska Sp. z o.o.

ul. Polczyhska 116  
PL-01-304 Warszawa  
Tel : +48 22 6652 609  
Fax: +48 22 6649 612  
E-Mail: bwt@bwt.pl

### BWT Hungária Kft.

Keleti út. 7.  
H-2040 Budaörs  
Tel : +36 23 430 480  
Fax: +36 23 430 482  
E-Mail: bwt@bwt.hu

### BWT UK Ltd.

Coronation Road, BWT House  
High Wycombe  
Buckinghamshire, HP12, 3SU  
Tel : +44 1494 838 100  
Fax: +44 1494 838 101  
E-Mail: info@bwt-uk.co.uk

### BWT Nederland B.V.

Centraal Magazijn  
Energieweg 9  
NL-2382 NA Zoeterwoude  
Tel : +31 88 750 90 00  
Fax: +31 88 750 90 90  
E-Mail: sales@bwt nederland.nl

### BWT AQUA AG

Hauptstraße 192  
CH-4147 Aesch  
Tel : +41 61 755 88 99  
Fax: +41 61 755 88 90  
E-Mail: info@bwt-agua.ch

### OOO Russia BWT

Ul. Kasatkina 3A  
RU-129301 Moscow  
Tel : +7 495 686 6264  
Fax: +7 495 686 7465  
E-Mail: info@bwt.ru

### Cilit S.A.

C/Silici, 71 -73  
Poligono Industrial del Este  
E-08940 Cornelia de Llobregat  
Tel : +34 93 440 494  
Fax: +34 93 4744 730  
E-Mail: cillit@cillit.com