

A close-up photograph of water splashing, with a hand visible on the right side, set against a blurred background. The water is captured in mid-air, creating a dynamic and refreshing scene.

Alternative Water Treatment





PHYSICAL WATER CONDITIONERS

Physical water conditioners are available in a variety of sizes and types. The final choice of model should take into consideration a number of factors including water hardness, flow rate, pipe size, pressure and system design.

THERE ARE FOUR MAIN TYPES OF WATER CONDITIONER:

electromagnetic, magnetic, electrolytic, and electronic. These types of devices are often referred to as scale inhibitors. They work by altering the characteristics of the hardness minerals within the feed water to help prevent limescale forming. Unlike a water softener, a scale inhibitor will not soften the treated water. Instead, the benefits are derived from the reduction of deposited hard scale within the treated water system.

BWT have also developed an additional technique for scale prevention and control. By using unique, three phase technology, the revolutionary AQA Total stabilises water by forming nanocrystals, making limescale unable to be deposited in installations.

Physical water conditioners offer a range of benefits including low running costs, simple installation and require minimal maintenance. Chemical free operation ensures the composition of the treated water remains unchanged which is particularly important on potable water supplies. The flexible nature of their design makes physical water conditioners suitable for a wide range of applications and pipe sizes. It is not uncommon to use more than one type or size of unit to protect different areas of large and complex system and in particular, where the system has a secondary return.

TYPICAL APPLICATIONS

- Heat exchangers
- Central heating systems
- Hot water heaters
- Electric showers
- Immersion heaters
- Hot water cylinders

MARKETS

- Hotels
- Offices
- Local authorities
- Leisure centres
- Schools and colleges
- Sheltered housing
- Prisons
- Manufacturing
- Public buildings
- Hospitals

AQA Total Energy



AQA Total Energy 1500

WITH REVOLUTIONARY, UNIQUE 3-PHASE-TECHNOLOGY

AQA Total Energy offers optimum limescale and corrosion protection for your drinking water installation whilst retaining all of its original mineral content, ensuring you get the most from your water.

OPTIMAL LIMESCALE PROTECTION

Due to its revolutionary bipolar technology, the limescale in the water is stabilised by forming nanocrystals, making it unable to deposit itself in the pipes, installation or boiler.

EFFICIENT CORROSION PROTECTION

The AQA Total creates an effective corrosion protection coating in metallic pipes for an increased lifespan.

DRINKING WATER PACKED WITH VITAL INGREDIENTS

AQA Total Energy keeps all essential mineral content in your water, helping you maintain your mineral intake from your drinking water.

MAINTENANCE FREE PROTECTION

With a long life refill cartridge and no salt or brine tank to maintain, the AQA Total offers a convenient way to get effective limescale and corrosion protection.



AQA Total Energy 1500

FEATURES AND BENEFITS:

- Fully automatic
- Low energy costs
- No down time, and is online 24 hours a day
- Chemical free protection against water hardness
- Easy to operate
- Ideal for use with modern heating units with built in storage and pumps

THE PROCESS

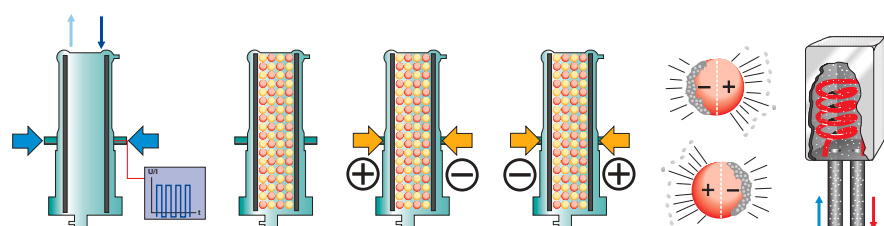



AQA Nano Limescale Protection

AQA Nano Limescale Protection System

The AQA Nano alternative limescale protection system prevents limescale and corrosion deposits in pipes and boilers in areas with water hardness of up to 350ppm.

SAFE reliable protection against limescale, blocked pipes and the unnecessary hygiene risks caused by deposits.

DRINKING WATER QUALITY

GUARANTEED all valuable minerals are retained in the water.

CONVENIENT the electronic controller provides a reliable reminder of an annual service.

EFFECTIVE LIMESCALE PROTECTION UP TO 350PPM

TYPE AQA TOTAL ENERGY		AQA NANO
Nominal width	DN	25
Nominal connection		1"
Nominal flow rate per DIN 19636 (EN 14743)	l/h	1500
Treatment capacity to max. 22°dH	m ³	110
PN operating pressure PN	bar	16
Dimensions (H x B)	mm	300x710
ORDER NO.		23301

AQA NANO LIMESCALE PROTECTION UNIT

ORDER NO.	23937
-----------	-------

1 limescale protection unit cartridge system. The used cartridge systems can be disposed with domestic waste or recycled with plastics.

AQA Total Energy

1500/ 2500/ 4500

The AQA Total is a series of environmentally friendly and safe drinking water treatment system. It offers pipes, boilers and installations full limescale protection by forming nanocrystals, ensuring limescale remains in the water, not in the pipe or boiler. In addition to this, it also creates a natural formation of an effective protective coating in pipes to prevent corrosion and help prolong lifespan. With the unique 3 phase technology, the AQA Total provides vitality in drinking water by retaining all of the valuable minerals found in drinking water without the use of chemicals or salt.



AQA Total Energy 4500

1 limescale protection unit cartridge system. The used cartridge systems can be disposed with domestic waste or recycled with plastics.

TYPE AQA TOTAL ENERGY		1500	2500	4500 L*	4500 R*
Nominal width	DN	25	25	40	40
Nominal connection		1" male	1 1/4" male	1 1/2" male	1 1/2" male
Accommodation		1	2-4	5-12	5-12
No. of unit modules		1	1	2	2
Flow rate	l/h	1500	2500	4500	4500
Dimensions (H x W x D)	mm	1100x320x200	1130x310x280	1105x320x320	1105x320x320
Treatment capacity	m ³	380	380	760	760
ORDER NO.		80007	80008	80009	80006

*L= Flow direction from left to right, R= Flow direction from right to left

ORDER NO.	84130
-----------	-------

AQA Total Energy

5600-8400/11200-14000

Wall-mounted unit (in quick mounting frame), distribution pipe system made of highquality yellow brass casting. Modular construction with integrated shut-off set and water meter (no water shut-off in case of cartridge exchange, no by-pass necessary). The modules are connected with the patented rapid connection system. Water connection on left or right, as required. Scope of delivery includes connection unions with male thread and cover for dust protection.

CONTROL SYSTEM Ready for installation in a standard control panel (safety class IP 54). Power electronic with separate fuse protection for each module; the whole system is controlled and monitored by one central processor. Completely electrically wired, connection 230 V/50 Hz. Connection for building automation (pre-warning in case of cartridge exchange and fault indication). Control lamps on the cabinet door.

FOR ALL TYPES Nominal pressure PN 10, water/ambient temperature max. 30/40°C, mains connection 230/50 V/Hz, electrical power rating 60 W, power consumption 0.055 kWh/m³, safety class IP 54.



AQA Total Energy
5600-14000
(Tested to DVGW 512)

OPTIMUM
PROTECTION
AGAINST
LIMESCALE

EFFICIENT
CORROSION
PROTECTION

DRINKING WATER
RICH IN VITAL
MINERALS

TYPE AQA TOTAL ENERGY		5600	8400	11200	14000
Nominal width	DN	40	40	50	50
Nominal connection		1 1/2" male	1 1/2" male	2" male	2" male
Accommodation		13-18	19-24	25-36	30-50
No. of unit modules		2	3	4	5
Flow rate	l/h	5600	8400	11200	14000
Dimensions (H x W x D)	mm	1280x560x470	1280x560x470	1280x825x470	1280x825x470
Treatment capacity	m ³	1150	1725	2300	2875
ORDER NO.		80010	80011	80012	80013

CARTRIDGE REFILL FOR AQA TOTAL ENERGY

5600 - 14000

With the new generation AQA Total Energy, the cartridge replacement, which is required for hygienic reasons, is simple. Only the working unit, so-called cartridge refill, must be changed. This new cartridge refi II for AQA total Energy ensures permanent constant efficiency, that means:

PHASE 1 for limescale protection – through stabilisation of the lime particles in the water
PHASE 2 for corrosion protection – through the natural formation of an effective protective coating
PHASE 3 for vitality – through optimisation of magnesium and oxygen

TYPE CARTRIDGE-REFI LL AQA TOTAL ENERGY	5600 - 14000
ORDER NO.	84131



AQA Total Energy
5600-14000
(Tested to DVGW 512)



- LCD display
- Volt free contacts for remote monitoring
- WRAS approved
- Suitable for pipe sizes from 3/4" to 4"
- Flow rates up to 30.5 l/sec
- Can help reduce plant downtime and prolong plant life
- With no by-products or consumables, the Powermag is environmentally friendly
- 100% conditioning
- Sensitive temp shut off avoids Legionella
- Stainless Steel Core

POWERMAG Electromagnetic Scale Inhibitor

The Powermag electromagnetic physical water conditioner uses the principles of magnetism to inhibit formations of crystalline scale within hot and cold water services. When the untreated water passes through the conditioning chamber, the scale forming elements molecular structure is altered, so that scale-forming particles do not readily precipitate as hard scale forming deposits.

The Powermag allows the magnetic flux generated by an internal coil to interface with the water as it passes through the conditioning chamber. The 360-degree magnetic flux is specifically sized to meet a range of water flow rates, determined by pipe size and site conditions.

Energy efficiency is optimised by the use of constant temperature monitoring within the unit, thereby ensuring lower running costs. Water treated by the Powermag remains potable, so it can also be used in drinking water situations.

The Powermag is an in-line conditioner with a full bore flow, so does not require a bypass or separate drain. BWT recommends fitting isolating valves before and after the unit to facilitate servicing.

All models come complete with a control panel which shows important operating information for the unit including running temperature, coil current, set temperature, coil status and hours run.

NOTES:

- All units operate on a 230v /50Hz power supply
- Maximum operating water temperature 25°C
- Maximum operating pressure 16 BAR
- Control panel 300 × 325 × 225mm (h x w x d) 10kg

**When compared with a similar piece of straight pipe*

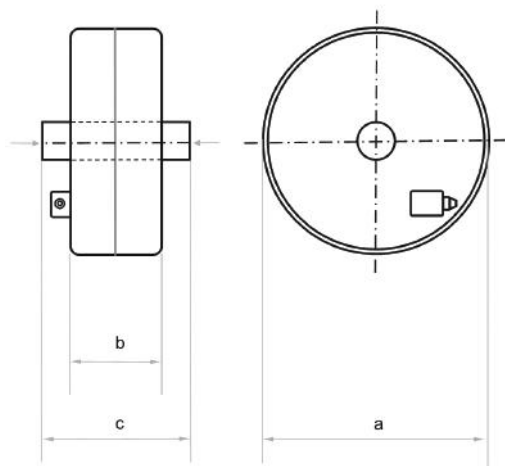

MODEL	INLET/OUTLET PIPE SIZE BSP (Male)	MAX FLOW RATE (l/s)	COIL SIZE (DxWxL)	COIL WEIGHT (Kg)	FRICTIONAL LOSS (BAR)	FUSE RATING (amps)	POWER CONSUMPTION DIAMETER WIDTH LENGTH (watts)
PM75	3/4"	0.5	62×50×240	5	0.1	3	50
PM100	1"	1.5	324×140×180	9.24	0.1	10	200
PM150	1.5"	3.0	324×175×240	19.8	0.1	20	200
PM200	2"	6.0	324×225×330	20.4	0.1	20	200
PM250	2.5"	8.0	324×225×330	23.5	0.1	20	200
PM300	3"	15.0	324×225×330	24.26	0.1	20	200
PM400	4"	30.5	324×225×330	27.1	0.1	20	200

WRAPPA Electronic Scale Inhibitors



WRAPPA Electronic scale inhibitors



Limebeater Electrolytic Scale Inhibitor

The Wrappa series of modern electronic scale inhibitors have been developed to help protect pipes and appliances from the build-up of scale, without the need for extensive maintenance or chemicals. After being fitted to either PVC, copper or iron pipework using the antenna supplied, the WRAPPA creates an electromagnetic field whilst passing swept frequency radio waves into the water, altering the morphology of the scale forming calcium and magnesium salts, and inhibiting their ability to form hard crystalline scale.

- Simple and quick installation – no need to cut the pipe or interrupt the water flow, making it ideal for existing installations
- Maintenance free
- Water remains potable
- Can be used in isolation to protect individual appliances or in conjunction to help maintain conditions in larger water systems
- Suitable for pipe sizes up to 108mm
- Flow rates up to 4.2 l/sec
- Programmable
- With no by-products or consumables, the Wrappa is environmentally friendly

MODEL	PIPE SIZE (mm)	MAX FLOW RATE (l/s)	POWER CONSUMPTION (mw)	FUSE RATING (amps)	SIZE (LxWxD) (mm)	WEIGHT (g)
LW2	Up to 35	0.8	30	3	120x80x46	462
LW10	Up to 76	2.5	48	5	221x157x87	596
LW20	Up to 108	4.2	48	5	221x157x87	596

Limebeater Electrolytic Scale Inhibitors

The Limebeater in-line range of electrolytic scale inhibitors offer a simple solution to limescale management using an electrolytic principle. The Limebeater induces an electromagnetic field to change the way scale forms by altering the alignment of the mineral molecules during crystalline formation. Molecules are encouraged to form long chains which develop into sharp thin crystals called "Aragonite" which, due to their shape, are less likely to form hard, insulating scale than the more common and naturally occurring calcite crystals they replace.

- Maintenance free
- Simple, unobtrusive design, making it ideal for plant rooms where space is limited
- 15 and 22mm WRAS approved*
- Suitable for pipe sizes from 15 to 54mm
- Flow rates up to 2.8 l/sec.
- Environmentally friendly
- Water remains potable
- Single appliance or partial system protection

MODEL	COMPRESSION FITTINGS (mm)	DIAMETER (mm)	LENGTH INCLUDING FITTINGS (mm)	MAX FLOW RATE (l/s)
LBC2-15V2	15	35	150	0.6
LBC2-22V2	22	235	154	0.6
LBC28	28	41	314	1.08
LBC35	35	41	314	1.08
LBC42	42	67	408	1.60
LBC54	54	67	536	2.80
PUSH - FIT				
LBC2-15	15	35	160	0.6
LBC2-22	22	35	167	0.6

*Selected models only please ask for details



BWT UK Limited

BWT House, The Gateway Centre,
Coronation Road, High Wycombe,
Buckinghamshire, HP12 3SU

☎ 01494 838 100

✉ commercialuk@bwt-uk.co.uk

bwt.com

FOR YOU AND PLANET BLUE.

BWT 2020 in the interests of product development we reserve the right to alter specifications without prior notice.
All photographs and dimensions are given for guidance only.
Terms and conditions apply E&OE.

ME0179/CAT