

# BWT pro-soft 11



Fitting and operating instructions **EN**

For You and Planet Blue.

 **BWT**  
BEST WATER TECHNOLOGY

## Table of contents

<b>Chapter 1: Introduction</b> .....	<b>2</b>
1.1 General comments .....	2
1.2 Manufacturer .....	2
1.3 Safety instructions.....	2
1.4 Intended use .....	2
1.5 Scope of delivery .....	3
<b>Chapter 2: Quick Operation</b> .....	<b>4</b>
2.1 Display and control elements .....	4
2.2 Standard factory settings.....	4
2.3 Programming procedure.....	5
<b>Chapter 3: Installation</b> .....	<b>6</b>
3.1 Installation requirements .....	6
3.2 Initial commissioning .....	6
3.3 Installation and operation considerations .....	7
3.4 Installation Layout.....	7
3.5 Technical overview of device .....	10
3.6 Installing your softener .....	11
<b>Chapter 4: Operation</b> .....	<b>12</b>
4.1 Functions and features .....	12
4.2 Operation (work ow) .....	13
4.3 Setting the hardness of blended water .....	14
<b>Chapter 5: Maintenance</b> .....	<b>14</b>
5.1 Maintenance work .....	14
5.2 Operator responsibilities .....	14
5.3 Maintenance and wearing parts .....	14
5.4 Disposal and environmental informations .....	14
<b>Chapter 6: Fault finding</b> .....	<b>15</b>
6.1 Trouble shooting Guide.....	15
<b>Chapter 7: Technical data</b> .....	<b>17</b>
7.1 Technical data of BWT pro-soft 11 .....	17
<b>EC declaration of incorporation</b> .....	<b>18</b>

## 1. Introduction

### 1.1 General comments

Please read this manual carefully and familiarise yourself with the operating instructions before using the BWT pro-soft 11 equipment.

The local standards as well as technical specifications have to be observed.

The operating instructions must be read in conjunction with any national regulations concerning accident prevention and environmental protection.

Prior to putting the device into operation, read the operating instructions completely and thoroughly. Please keep this manual close to hand for quick reference to the unit's operation.

The device shall only be used for its intended purpose, in line with the operating instructions and only in the environment to which intended.

**Note:** Never exceed the defined maintenance and service intervals.

### 1.2 Manufacturer

#### **BWT UK Ltd.**

Coronation Road, BWT House  
High Wycombe  
Buckinghamshire, HP12, 3SU  
Phone: +44 / 1494 / 838 100  
Fax: +44 / 1494 / 838 101  
E-mail: info@bwt-uk.co.uk

### 1.3 Safety instructions



**Danger** caused by electric current or voltage!

Always consult a qualified electrician when working on places denoted by this symbol.

The complete power supply unit must be replaced in the event of damage to the mains cable.



**Warning:**

Do not use any aggressive cleaning agents!

If a power failure occurs when regeneration waste water and overflow are being drained into a sump, flooding may occur.



**Please observe:**

Use only trained or instructed staff. Stipulate clear staff responsibilities for operation, set-up, maintenance and repair work.



**Please observe:**

NEVER operate the device with the housing covers removed.



**Note:**

If needed, use protective clothing.



**Note:**

Additional information for the operator.

### 1.4 Intended use

The application BWT pro-soft 11 is designed for softening or partially softening domestic water (in accordance with the relevant regulations e.g. for drinking water). All other use is strictly forbidden and is your own responsibility.

## 1.5 Scope of delivery

**BWT pro-soft 11 water softer with:**

**Standard delivery:**

1. Multi-way control valve with microprocessor controller
2. Blending valve
3. Softening column with ion exchange resin
4. Softened water outlet
5. Hard water inlet
6. Drain water
7. Overflow connection
8. Mains plug power supply connection
9. Installation and Operating Manual (IOM)
10. Hose clamp connection
11. 2 m drain water hose (flexible)
12. Access cover with short user instructions
13. AQUATEST hardness tester

**Please open the access cover (12), (See page 27):**

14. Salt storage container
15. Cabinet
16. Fixing material (See page 27)
17. Rating plate and serial number (See page 27)

**Additional delivery:**

18. Non-return valve BSP:  $\frac{3}{4}$ " (DN: 20/20)

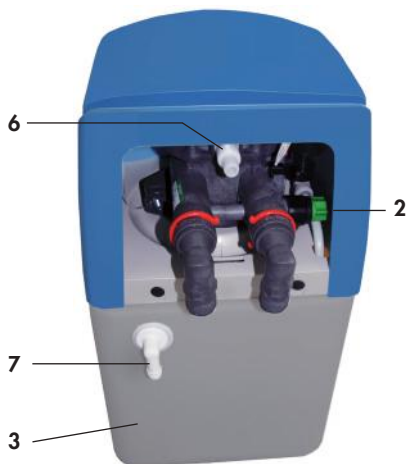

## 2. Quick Operation

### 2.1 Display and control elements

**Note:** In the programming mode the respective **>target value<** flash.

The display shows:

- the current time and
- the remaining capacity in %

[UP]	[DOWN]	[SET/RETURN]	[RECHARGE]
= Moves cursor changes entries		= Confirms entries	
		= Programming recharge tonight	

### 2.2 Standard factory settings

Duration of the step times:

Regeneration time:

Hardness of drinking water / capacity:

Depending on the internal settings of the unit (**a few minutes**)

free input at RECHARGE TONIGHT

300 ppm, 1566 litres for 10 litre model

BWT pro-soft 11	Standard	UK	EU
Display	Yes	Yes	Yes
Operating range	UK/EU	1.7 ... 5.0 bar	1.0 ... 8.0 bar
Recharge tonight	Yes	Yes	Yes
Salt alarm	No	OPTION	OPTION
Salt setting - care cubes (CC)	UK/EU	Yes	Yes
Salt setting - block salt (BS)	UK only	Yes	No

#### Note for the initial softener settings:

##### Setting the time of day:

On first powering up the softener the display will flash while the valve rotates to service position, the valve can be heard moving, **this can take a few minutes**. On locating service position the display will prompt the installer to set the time. Start by pressing the **SET/RETURN** key, this will make the hour digit to flash, press the **UP/DOWN** key to adjust to the correct hour, once set, press the **SET/RETURN** key, this will make the minutes digits flash, use the **UP/DOWN** key to adjust the minutes. Throughout the settings mode use the **UP/DOWN** keys on the softener display to toggle or adjust settings and use the **SET/RETURN** key to store the setting and move on to the next field in the menu.

## 2.3 Programming procedure

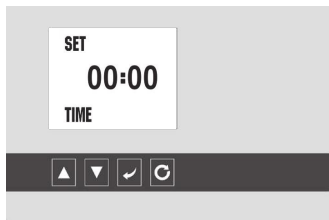

Fig 1



Fig 2

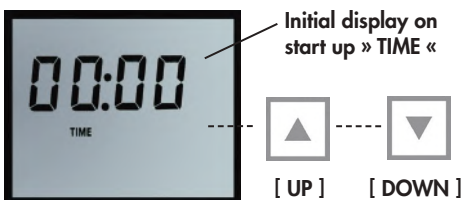

Fig 3



### 1. Setting the time of day (see Fig. 1)

The first **two digits (00)** of the display will flash prompting the installer to set the time.



The time is adjusted by using the [UP], [DOWN] keys. Pressing the [SET] key enters the hours.

The minutes are set by using the [UP], [DOWN] keys.



Pressing the [SET] key once enters the minutes and moves the display into the Set Hardness mode.



### 2. Setting the water hardness (see Fig. 2)

The display default is 300 ppm (typical hardness level) which indicates a setting suitable for hard water with a value of 300 parts per million of hardness minerals. Use the keys [UP] [DOWN] keys to adjust the setting to match that of the one you obtained / identified earlier. See **page 24** for details.



Pressing the [SET] set key once enters the hardness and moves the display to Set Recharge Time Mode.



### 3. Setting the recharge time (see Fig. 3)

To operate effectively, your water softener needs to regenerate periodically (dependent on the hardness of the supply and amount of water used). The default time of day when this is to occur is **2:00 a.m.**. To alter this setting use the [UP] [DOWN] keys.

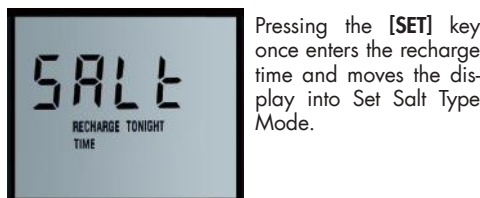
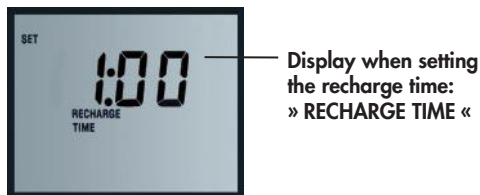

This option is only available on certain models - not standard.

## 3. Installation

### 3.1 Installation requirements

#### National guidelines and regulations:

Observe all applicable installation regulations, general guidelines, hygiene requirements, and technical specifications. The hard water to be fed into the unit must always meet the specifications of the national Drinking Water Ordinance or EU Directive 98/83/EC. The total dissolved iron and manganese may not exceed 0.1 mg/l. The hard water to be fed into the unit must always be free of air bubbles.

#### Frost protection and ambient temperature:

The installation site **must be free of frost** and kept free of chemicals, paint, solvents and fumes. The **ambient temperature should not exceed 40°C**, even before the machine is started. Please avoid direct heat sources, e.g. radiators and exposure to sunlight.

#### General safety:

The rated mains power (see technical data) and the requisite inlet water pressure must be present at all times. No protection against a lack of water is provided. This must be installed on-site if required.

#### Overpressure and fluctuation protection:

**Attention: Water pressure must never exceed the unit's maximum of 5.0 bar UK, 8.0 bar EU.**

If the network **water-pressure is higher than 4.0 bar UK, 6.0 bar EU** (or you are unsure about pressure), a pressure reducer (pressure reducing valve) must be installed upstream of the unit.

**During pressure fluctuations or surges, the sum of the pressure surge and the standing pressure is not to exceed the nominal pressure.**

#### Electrical interference:

The emission of interference (EMI = voltage peaks, high-frequency electromagnetic fields, interference voltages, voltage fluctuations...) by the surrounding electrical systems may not exceed the maximum values specified in EN 61000-6-3.

#### Data analysis of the hard water in your area:

Continuous operation of the water softener with water containing chlorine or chlorine dioxide is possible if the concentration of free chlorine/chlorine dioxide does not exceed 0.5 mg/l. **The type of pre-treatment must be determined individually.**

#### Principle of intelligent regeneration:

The unit should be sized according your current water consumption. If water consumption is reduced, e.g. during holidays, a shut-off device must be fully opened for at least 5 minutes before water can be used again.

#### Inlet- and outlet connections:

When installing the unit, select a location where the unit can easily be connected to the water supply network. A connection to the waste water system (**at least DN 50**), a floor drain and a separate mains socket (see technical data) must be nearby.

#### Overflow hose connection:

A suitable overflow hose connection is required to remove the waste water.

#### Preconditions for the hydraulic installation:

Observe the hydraulic and electrical requirements for installation for first commission. (see "chapter 5")

#### Exclusion of warranty:

**Non-compliance with the installation conditions and the operator responsibilities voids the warranty.**

#### Guarantee:

In the event of a malfunction of the unit during the guarantee period, please contact your **after-sales service department** and quote the model type and the **production number** (see technical data or the rating plate on unit).

**Note:** Only your local after-sales service staff may perform any works under the guarantee.

Any work performed by a third party must be directly commissioned by your after-sales service.

### 3.2 Initial commissioning

for professional installation by a qualified fitter.

- Has all **packaging material (16)** been removed from the brine cabinet?
- Is there a **protective filter** upstream from the unit in the immediate vicinity?
- Is the water and power supply to the unit continuous (**network pressure of at least 1.7 bar UK / 1 bar EU**)
- Have you opened the **pressure reducing valve** to the **limit stop**?
- Have the **water hoses** been **properly connected**?
- (Observe the flow direction arrows and hard water inlet at the non-return valve of the unit).
- Have the drain water hose and the overflow been routed separately to the waste water system and connected? (See Installation)
- Have you informed the operator of the inspection schedule? (Check supply of salt and hardness of blended water at least every two months)
- Have you informed the operator of the maintenance schedule? (Tasks in accordance with manufacturer's instructions. Interval annually, every 6 months with communal units)

Please check connections and pipeline junctions for leaks.

#### Handing over the unit to the operator:

If there is a delay between the installation/startup of the unit and transfer to the operator, a manual regeneration must be performed. The operator must be told how the unit works as well as how to operate and inspect it. Ensure that the operator receives the installation and operating manual.



#### Please open the access cover (12)

- 14. Salt storage
- 15. Cabinet
- 16. Fixing material (not seen)
- 17. Rating plate and serial number



### 3.3 Installation and operation considerations

#### 1. Before you begin

The installation of your new water softener is relatively straightforward. However, we would recommend that either a qualified plumber or a person with relevant plumbing experience carries out the installation.

Before embarking on the installation, please ensure you have familiarised yourself with both these instructions and the components required to complete the installation.

#### 2. Positioning the water softener

Please measure your water softener to ensure that it will fit into the area you are placing the unit into. PLEASE remember to include additional space for connecting pipe work in your calculations along with the regular access that is needed for topping the unit up with salt and future service.

Where possible, the distance of both the incoming water supply and nearest drain should be kept to a minimum. Two metres is an ideal distance, however, longer distances are permissible, dependant on the incoming water pressure.

Please remember the weight of your new water softener will considerably increase once installed and filled with salt. Therefore, please ensure your chosen location is strong enough to support an approximate total weight of (see table). Your new water softener has been designed to operate efficiently and effectively with an incoming water pressure of between **1.7 to 5.0 bar UK, 1.0 to 8.0 bar EU**. If your water supply is likely to fall outside these limits, then we would recommend that a **booster pump or pressure reducing valve should be fitted respectively**.

Operating  
pressure  
3.5 bar UK /  
4.5 bar EU

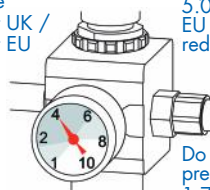

If pressure more than:  
5.0 bar UK / 8.0 bar  
EU install pressure  
reducing valve

Do not operate with a  
pressure less than:  
1.7 bar UK / 1.0 bar EU

Important - Never install the water softener where it, or its connections (including the drain overflow lines) will be subject to temperatures under 0°C or above 40°C.

If you are planning to install the water softener above ground level e.g. In the loft, the following instructions should be strictly adhered to.



### 3. Loft installation

The water softener should be installed within a container of not less than 100 litre capacity, to which there should be connected an overflow pipe of not less than 20mm diameter. The overflow should be connected at the bottom of the container and not less than 15mm below the height of any electrical components mounted on the water softener. It is recommended that an anti vacuum valve be fitted to the inlet pipework supplying the water softener.

### 4. Plumbing systems

There are several types of plumbing systems in common use:

For 15mm pipework (e.g. Static Head systems) The water softener can be supplied optionally with a high flow installation kit and flexible high flow hoses suitable for 22mm pipework, for 15mm pipework use the reducing bushes supplied with the kit, (see diagram on [page 29](#)).

### 5. Backflow prevention device

When fitted to the supply feeding a single dwelling, a check valve complying with national regulations must be fitted on the cold water feed prior to the installation. All other types of installation require the fitting of a double check valve.

### 6. Drinking water

Your water softener installation must include at least one drinking water tap that is not fed by the water softener.

**Observe:** In case of **low sodium diet** follow the local "department of health's" advice concerning the use of softened water for drinking.

**Note:** Water that is used for mixing powdered milk for **babies** must only be taken from an unsoftened mains tap as some powdered milks and softened water both **contain sodium for which young babies have a limited tolerance.**

## 7. Reference Data for Hardness Adjustment

Please test the water hardness and, if required, use the chart to convert hardness settings to „parts per million“ (ppm) and refer to [chapter 4.3](#).

The specific hardness conversion chart for capacity of the time-clock operation is listed in the last column.

BWT pro-soft 11			10 litres
M3/°F			(50)
d°H	f°H	ppm (mg/l)	capacity
5.6	10.0	100	5000
6.2	11.0	110	4545
6.7	12.0	120	4167
7.3	13.0	130	3846
8.4	15.0	150	3333
10.1	18.0	180	2778
11.2	20.0	200	2500
12.3	22.0	220	2273
13.4	24.0	240	2083
14.6	26.0	260	1923
15.7	28.0	280	1786
16.8	30.0	300	1667
17.9	32.0	320	1563
19.0	34.0	340	1471
20.2	36.0	360	1389
21.3	38.0	380	1316
22.4	40.0	400	1250
23.5	42.0	420	1190
24.6	44.0	440	1136
25.8	46.0	460	1087
26.9	48.0	480	1042
28.0	50.0	500	1000
29.1	52.0	520	962
30.3	54.0	540	926
31.4	56.0	560	893
32.5	58.0	580	862
33.6	60.0	600	833

## 3.4 Installation Layout

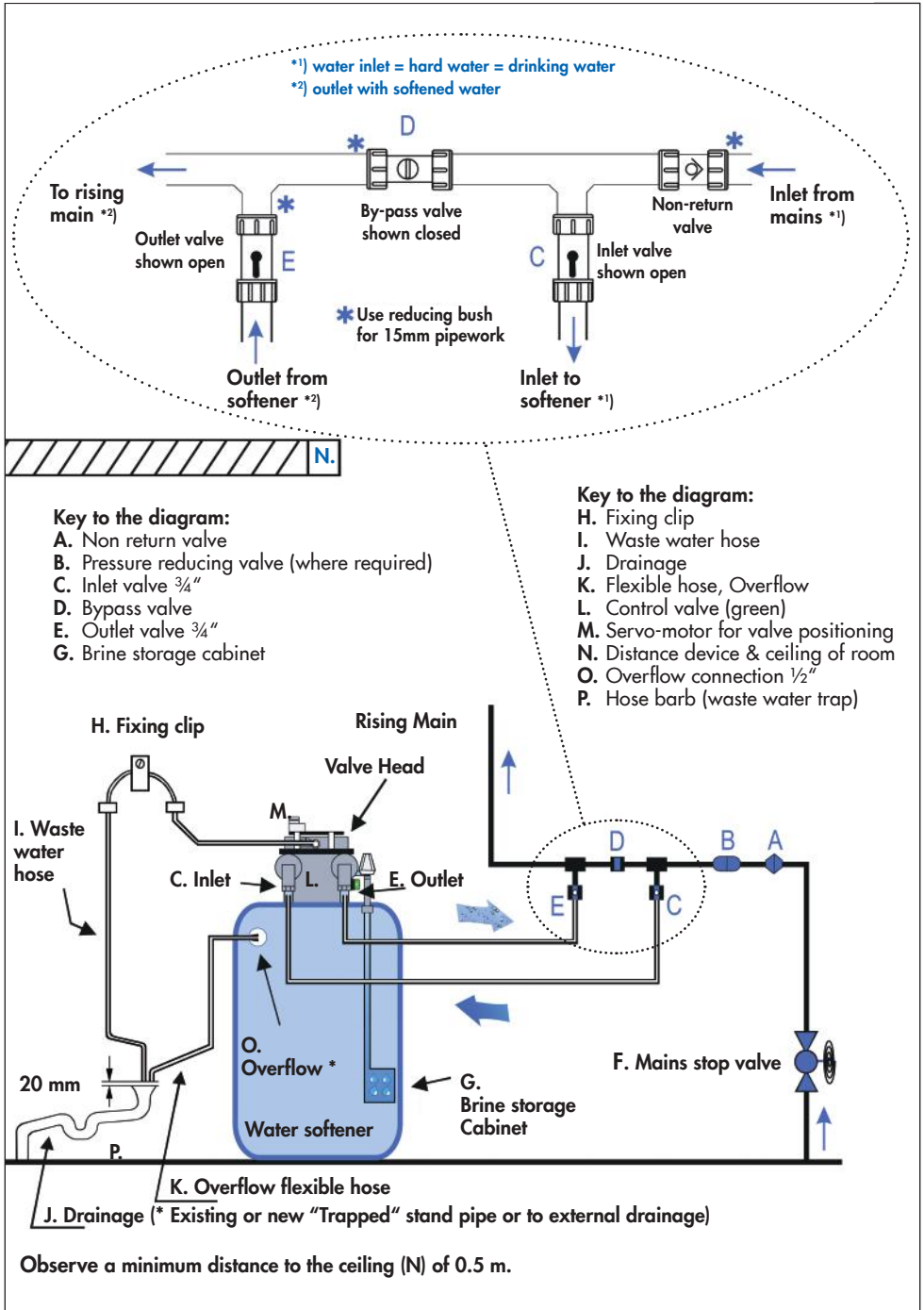

### 3.5 Technical overview of device:

- |  |  |
|--|--|
| <b>C.</b> Inlet connection (feed water)      | → for flexible hose, with thread $\frac{3}{4}$ " |
| <b>E.</b> Outlet connection (softened water) | → for flexible hose, with thread $\frac{3}{4}$ " |
| <b>G1.</b> Brine storage cabinet             | → salt filling                                   |
| <b>G2.</b> Connection to brine               | → internal connection                            |
| <b>O.</b> Overflow connection                | → for flexible hose, threadless $\frac{1}{2}$ "  |
| <b>L.</b> Control valve                      | → flow regulation                                |
| <b>M.</b> Servo motor                        | → for control valve                              |
| <b>I.</b> Waste water connection             | → external drainage of waste water               |

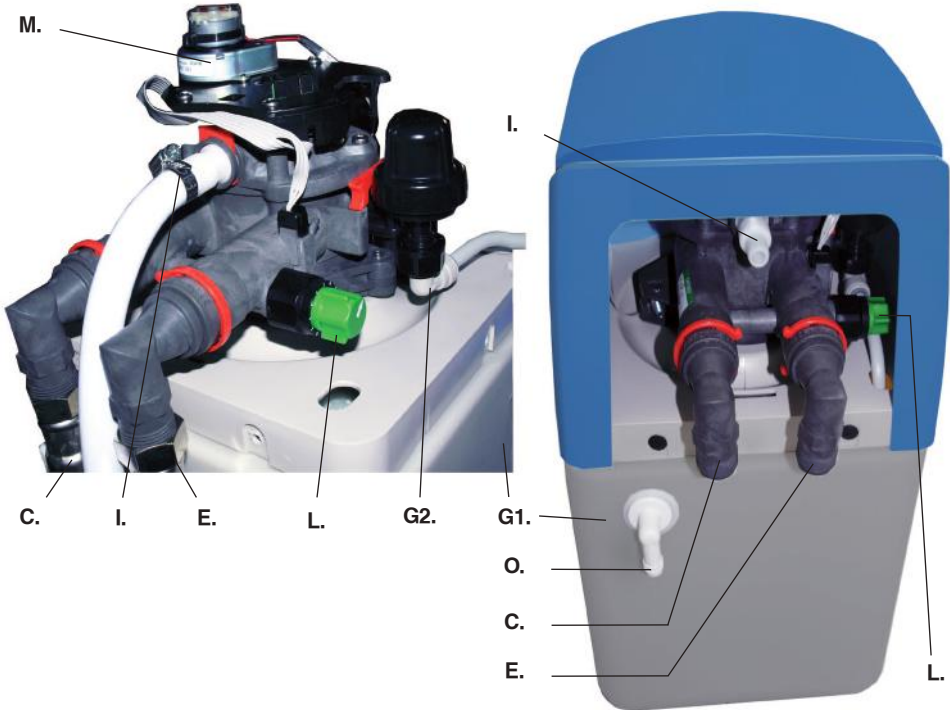

**Attention:** Pipework (J) sized min. DN50. Use only the flexible DN20 hoses included in the delivery. Ensure a correct sealing and setting of all pipes before first commissioning.

**Attention:** To comply with good plumbing practice the external waste-water-drainage must have a minimum space of air: 20mm (according to guideline EN 14743).

**Attention:** Drainage from the overflow of the brine tank, Connections between the channel and two flexible hoses (according to standard EN 3131).

**Protection of device:** To increase the lifetime of your softener ensure it is kept in a clean, dry place with an ambient temperature between 5 and 40°C. Do not mention damage to resin or components.

### 3.6 Installing your softener

#### 1. Positioning the water softener:

It is very important to establish the water pressure before installing the water softener. If the water pressure is low then the water softener may not operate effectively. If it is too high, then components inside the unit may be damaged.

Water pressure should be tested with a gauge at the kitchen tap or outside tap. It should be noted that water pressure can increase at periods of low water usage e.g. overnight. **If therefore, the daytime pressure exceeds 5.0 bar UK, 8.0 bar EU or if you are unsure about pressure, then a pressure reducing valve should be fitted.**

Where the pressure is less than **1.7 bar UK, 1.0 bar EU** a booster pump may be required.

#### 2. Inlet and outlet connections:

With the bypass valve open and the inlet / outlet valves closed the unit can be connected to the plumbing system. Arrows on the inlet and outlet piping from the valve will confirm the direction of flow.

Connections can be made with either conventional copper tube and fittings or the high flow flexible hoses supplied, ensure hoses are not kinked as this may restrict flow.

#### 3. Drain connection:

Push the flexible drain hose onto the barbed connector (Drain) as shown on **page 29** and secure with the clip provided. Run the drain hose to a stand pipe or to a drain. **The air gap needs to be at least 20 mm.** Softened water will have no adverse effect on a septic tank. You can extend the drain up to 9m if you have sufficient pressure (greater than **3 bar**). The drain hose must not be kinked or restricted in any way as this will cause an overflow from the brine cabinet.

#### Frost protection:

If the drain hose or connecting pipework is likely to be subject to **temperatures below 0°C it must be protected** to prevent freezing. Failure to observe this precaution could lead to the water softener overflowing.

#### Raising the drain hose:

If you have a water pressure of **3 bar** or more, you can raise the drain to a maximum of 3 metres above the valve head.

#### 4. Overflow connections:

The hose barb overflow pipe (not supplied with the softener) should be connected to the push fit elbow at the rear of the cabinet (see **page 30** – letter O). Run the pipe downhill to the drainage. Take care that the overflow does not discharge where damage could occur.

If the water softener is fitted in a cellar or basement, the overflow can be run to a storage tank. Do not elevate the overflow hose.

**Note:** Do not use jointing cement on the fitting.

#### 5. Electrical connections:

For added safety, peace of mind and ease of installation, your water softener is powered by low voltage via a plug in transformer. This transformer must be connected to a switched socket.

**Attention:** Plug the transformer into the socket with the switch in the **OFF-position**.

#### 6. Filling the brine cabinet, salt- usage and alarm:

Now place the water softener salt in the brine cabinet. Use the care cubes (tablet salt) or block salt (UK), from your local dealer.

**Notes on salt usage:** Your water softener will only perform effectively if there is salt in the brine cabinet during the regeneration process.

It is therefore essential that the salt level does not fall lower than 15 cm in depth when measured from the base of the brine cabinet. **N.B. The softener requires no priming, add no water to the brine tank.** During regeneration, salt will not enter your water system as the salt used in the regeneration process is rinsed safely away to drain.

#### Salt alarm is optional - not standard on most models.

Depending on your model your water softener may be equipped with a low salt alarm, this monitors your salt usage and sounds an audible alarm while displaying the low salt error code “**SALT**” when your salt levels falls to the minimum level. **To reset the salt alarm fill the system with salt and press the SET-key.**

#### 7. Blending control:

All machines are factory set to produce water that is soft. **Note:** If you prefer water which is less soft, turn the blending knob on the left side of the valve anti-clockwise until the water meets your requirements.



#### 8. Testing for the water hardness in your area:

Water hardness can vary from one location to another. To determine the hardness of the water feeding your water softener (unsoftened supply) use the hardness test kit supplied.

- Fill the test bottle supplied to the fill line with water from a hard water tap.
- Add the tablets to the solution one tablet at a time.

- Shake the bottle in between and keep adding tablets to the water until the solution turns from wine red to blue, record the number of tablets as you go.
- Using the data table supplied with your kit, match up the number of tablets with the hardness. You will need this figure when programming your water softener in the next section of this manual.

## 9. Switching on for the first time:

- Check that the **inlet hoses and outlet hoses or couplings** are **properly connected** i.e. inlet-to-inlet, outlet-to-outlet.

The **by-pass arrangement** (see page 29) should be **in the open position** in example:

- the **inlet- and outlet valves closed** (E), (C)
- Check that the **by-pass valve** (D) open
- Check that the **mains stop valve** (F) open.
- Check that the **Brine Cabinet** (G) contains salt.
- Check that the **water softener is connected to the drain** (J) and the **overflow pipe** is be linked to each other **connected**.

**Note:** The drain and overflow must not be linked to each other.

- Gently open the **inlet valve** (C) so that water flows into the **resin vessel**.
- Turn **ON** the power, you will hear the valve move quietly into the start position. When the positioning process has been completed (which can take up to 5 minutes) you will hear the movement stop, **the valve has now reached its start position** in preparation for the programming procedure.
- Close the **by-pass valve** (D).
- Gently open the **outlet valve** (E).
- Check for leaks, take corrective action to stop leaks if required.
- Your **water softener is now on line** and you may start the valve **programming procedure** set out in the next section of this manual.



Lift off this cover and connect the jack plug of the lead to the control box behind the front panel



## 4. Operation

### 4.1 Functions and features

#### Capacity requirement-dependent of the unit controller:

The unit operates according to the principle of intelligent regeneration. The average capacity level of each model is preset and updates automatically to the actual consumption within 14 days.

The presetting is appropriate for the most common applications. It is not necessary to adjust the unit for individual requirements.

#### Intelligent quantity-dependent regeneration:

When the unit is started, the available supply of softened water is programmed (depending on the hardness of the water).

At a user-defined time (e.g. at night), the unit checks whether the remaining supply of softened water is sufficient for the following day. If this is not the case, the softening column is regenerated by only the exact percentage necessary to fully replenish the supply of softened water to 100%.

**Note:** With intelligent regeneration, the remaining supply of softened water is not wasted.

This intelligent regeneration method is possible because of the precision flowmeter, which is able to adjust the amount of brine required for partial regeneration. The consumption of regenerative and water is reduced to the required minimum.

In the event of a power failure, the data and the time are retained (for approx 72 hours).

**Options:** The unit is optionally equipped with a device that disinfects the ion exchange resin during the regeneration. A spring-loaded **non-return valve (18)** is optionally available (see page 23).

#### Automatic regeneration triggering:

This is an optional setting - not as standard on all softeners.

### 4.2 Operation (workflow)

#### Setting the Type of Salt used:

To operate effectively, your water softener must be set to the type of salt you intend to use in the system. **Salt pellets are suitable.**

Pressing the **[SET]** button will return the display to the Normal Operation mode. Programming is now complete and no further adjustment of the water softener is required. Remember to check the salt and water level in the brine cabinet weekly.

**Charge Bar:**

Having set the display on the control fascia, you will notice that during normal operation there is a charge bar running along the bottom of the display. This charge bar shows the percentage of water softener capacity remaining since the last regeneration. Immediately following a regeneration, the charge bar returns to 100%.

**Resetting the display during operation:**

If the time is to be adjusted during normal operation, press any key to illuminate the display, press the [SET] key once. The display will flash and indicate present time. Using the keys will alter the time as described on [page 24](#).

**Power loss:**

The AMECS system will maintain the individual programming parameters of the water softener for up to 72 hours.

If the power cut lasts longer than 72 hrs, the control will flash "00:00" when power is returned to the control. The unit will continue to keep time from the moment power is restored. In this situation the time of day will need to be reset.

**Flow indicator:**

During normal operation, a flow indicator will flash on the display at a rate of one litre per pulse when water is passing through the softener.

**Cleaning:**

Your water softener may be cleaned using a damp cloth and a mild detergent. Do not use bleaches, solvents or spirits as they may damage the surfaces.

**Manual regeneration [recharge] button:**

Under normal operating conditions your water softener will regenerate automatically and you should not normally have to regenerate the unit manually. If however a manual regeneration is required then follow the procedure set out below.

1. Press any key to illuminate the display.
2. Momentarily pressing the button (symbol underneath the display and furthest to the right) will illuminate Recharge Tonight on the display and perform a regeneration at 2.00 a.m. regardless of the remaining water softener capacity.
3. If the button is subsequently pressed, this will clear the Recharge Tonight indicator from the display and cancel the Recharge Tonight feature.
4. If the [recharge] button is pressed down for six seconds, the controller will flash the Recharge display and immediately commence the regeneration cycle which cannot be cancelled.

**Adding regenerative salt:**

Refill the salt no later than when **SALT** is indicated on the display or the current filling is 15cm above the base of the salt storage container.

**Acknowledge - low SALT alarm:**

**NOTE:** This function is optional - not standard on all models.

Open the **cover (4)**. Pour regenerative into the **storage area (5)**.



Press [SET] and hold until the **SALT** display goes out. Refill the unit in such a way that no dirt can get into the **storage area (5)** (if necessary, clean the packages containing the regenerative before use).

**Clean the storage area or brine cavity (6) with clean water if it gets dirty.**

**Salt usage:**

Your water softener is controlled by a microprocessor which constantly monitors water usage.

The system will build up a history of your water requirements and calculate the most economical regeneration pattern. This will ensure a constant supply of softened water whilst maintaining high levels of water and salt efficiency. As your water softener uses a proportional brining system, more frequent regenerations do not necessarily mean high water / salt usage.

**Increase in number or residents:**

Sudden changes in your water usage should not affect your water softeners performance. If however, the number of guests staying with you increases, you will notice that the water usage patterns will alter. This may cause your water softener to regenerate more often than normal. As the water usage returns to its normal level, the number of regenerations will also return to normal.

**Cabinet Water Level:**

During normal operation the water level inside the water softener cabinet will rise and fall as required by the regeneration process. If the water softener is used within the specified operational parameters the water level should not reach the overflow connection. If however an overflow situation occurs please refer to the **troubleshooting section on page 35 to diagnose the problem.**

Following any overflow situation reduce the water level by half and initiate a manual regeneration as described above.

**NB:** Check the water level weekly and following any unplanned event, e.g. powerfailure.

### 4.3 Setting the hardness of blended water

The unit is preset to **300 ppm**.

To test the water hardness, allow the nearest cold water tap to run for a while and check the hardness of the blended water using the AQUATEST hardness tester.

Adjust with the blending valve "V" until the desired value is reached.

Hardness in ppm	Min., average and max. settings		
	Min.	Average	Max.
150	8	6	4
200	7	5	3
250	6	4	2
300	5	3	1
350	4	2	1
400	3	1	1
	= Days between regeneration		

**Note:** To transfer the water hardness  $d^{\circ}H$  and  $f^{\circ}H$  to ppm (mg/l) the table on page 28.

## 5. Maintenance

### 5.1 Maintenance work

The operator must regularly perform the following checks to guarantee that the unit functions properly.

**Check the regenerative and refill after use.**

**Check the water hardness:** The hardness of drinking water and the set blended water hardness must be checked 2x annually and the hardness of the blended water must be corrected when required (see Start-up).

**Check for leaks, visual inspection:** Check connection lines and connections for leaks. Check for dirt in the regenerative storage area and brine cavity every two months and clean and flush with clear water if necessary.

The intervals between checks are recommended minimums and must be adjusted according to site conditions.

### 5.2 Operator responsibilities

All technical equipment requires regular servicing in order to guarantee optimal functionality.

Keep yourself up to date with regard to the quality and pressure ratio of the water which is to be treated. If the water quality changes, the settings may need to be changed. Consult a specialist if this is the case.

Regular checks by the operator are required for the warranty and proper functioning of the unit. The water softener must be inspected regularly in accordance with the conditions of operation and use.

#### Operator checks intervals:

After use:	Refill regeneration salt
2x Annually:	Check pressure
2x Annually:	Check water quality
1x Annually:	Clean brine container

### 5.3 Maintenance & wearing parts

**Wearing parts must also be replaced within the prescribed maintenance intervals in order to guarantee functionality and fulfil the warranty conditions.** The water softener should be serviced once a year.

Wearing parts may only be replaced by qualified personnel (fitters or after-sales service team).

We recommend that you enter into a maintenance agreement with your fitter or the aftersales service team.

**Cleaning information:** Do not use alcohol or alcohol based cleaning agents, otherwise the plastic surfaces of the device will be damaged.

### 5.4 Disposal and environmental informations

At the end of product life please contact BWT Customer Services to arrange a new replacement for your softener.



Disposal of your softener and any electrical parts (e.g. 0.22µF capacitor battery, 5.5 V) should only be carried out at authorised WEEE recycling centres.

## 6. Fault finding

### 6.1 Trouble shooting Guide



**Attention:**

If your water softener is not performing as it should, please run through the check list below.

Checklist:	Solution:	Page:
<b>Problem: Water still remains hard.</b>		
Is there a minimum of 150mm of salt in the brine cabinet?	Fill the brine cabinet with salt.	11
Is the power on?	Switch the power on and check connections.	11
Is the softener online? Hydraulic problem during regeneration (e.g. pressure drop of water).	Close the by-pass valve and open the inlet and outlet valves. Please restart the regeneration manually.	11
Is the hardness setting correct?	Reset the hardness if required.	11, 14
<b>Problem: Water level in brine cabinet reaches overflow.</b>		
Is the line pressure within the specification of the water softener?	Connect a pressure gauge to a water outlet and check the pressure is between: 1.7 - 5.0 bar for the UK / 1.0 - 8.0 bar for EU.	6, 7, 8
Pressure falls outside of the water softener specification.	Fit a pressure reducing valve or booster pump as required. (observe the note below)	6, 7, 8
Is there flow through the drain line?	Check the drain line is not kinked, blocked or frozen.	9, 10
Has there been a power interruption?	Check that the power is on and the connections are secure.	6, 12
<b>Problem: No water.</b>		
Is the mains stop valve open?	Open the mains stop valve.	11
Are the inlet and outlet valves of the water softener open?	Open the inlet and outlet valves to the water-softener.	11



**Note:**

If any overflow situation occurs or if any of the above requires action reduce the water level by half and initiate a regeneration by pressing and holding the **manual regeneration key [RECHARGE]** for more than six seconds.



**Attention:**

If your water softener is not performing as it should, please run through the check list below.

Checklist:	Solution:	Page:
<b>Problem: Water runs from the drain constantly.</b>		
Is the unit in recharge mode?	If yes, this is normal, wait until the recharge is complete.	5
Is the power on?	There should be no flow to drain in the service position.	6
<b>Problem: Excessive salt usage.</b>		
Check the hardness setting.	Reduce the hardness if incorrect.	5, 14
<b>Problem: Electronic Display.</b>		
The display shows error code: <b>"Err 1"</b> , audible alarm sounds, (see note below).	Check all the connections are secure. Turn the power off for 10 seconds then turn back on, allow the system to reset.	13
OPTIONAL: The display shows error code: <b>"SALT"</b> , audible alarm sounds.	The low salt alarm is active. Fill the brine cabinet with salt. Pressing the <b>[SET]</b> key will reset the salt alarm to full capacity of salt.	13
Is the digital display blank?	Check the power is turned on and all the connections are secure.	13
<b>Problem: Unit regenerates at the wrong time.</b>		
Is the present time correct?	Reset the present time.	5

**Note:**

If the home position is **not detected within 10 minutes**, the main display will show an **"Err 1" message** to indicate a controller error and an audible alarm will sound. The error condition **can only be cleared by removing and re-applying the power.**

**Attention:**

If problem persists, please call your local dealer or after sales service team.

## 7. Technical data

### 7.1 BWT pro-soft 11

BWT pro-soft	Type	11
Nominal connection (outside thread)	BSP	¾" (DN 20)
Nominal flow rate in accordance with EN 14743	l/h	1440
Operating pressure EU (min./max.)	bar	1.0 / 8.0
Operating pressure UK (min./max.)	bar	1.7 / 5.0
Pressure drop down at nominal flow in accordance with EN 14743	bar	1.0
Quantity of ion-exchange resin	l	10
Nominal capacity (EN 14743) / (CaCO <sub>3</sub> mmol/l)	m <sup>3</sup> x°dH/mol/ppm	26 / 4.6 / 460
Capacity salt reservoir	kg	12
Salt consumption per regeneration *)	kg	1.5
Water consumption per regeneration *)	l	85
Protection class	IP	51
Water temperature (min./max.)	°C	5 / 30
Ambient temperature (min./max.)	°C	5 / 40
Electrical connection	V / Hz	230 / 50
Dimensions: Width x depth x height (W x D <sub>2</sub> x H)	mm	270 x 480 x 532
Connection height (A) / Overflow height (S)	mm	403 / 270
Operating weight, approx.	kg	40
<b>Order number :</b>		<b>820001</b>
*) Tested with "HiFlow" connection available in option		

\*\* gray and blue models are technically equal:  
The shown illustrations and the delivered components can vary in detail.

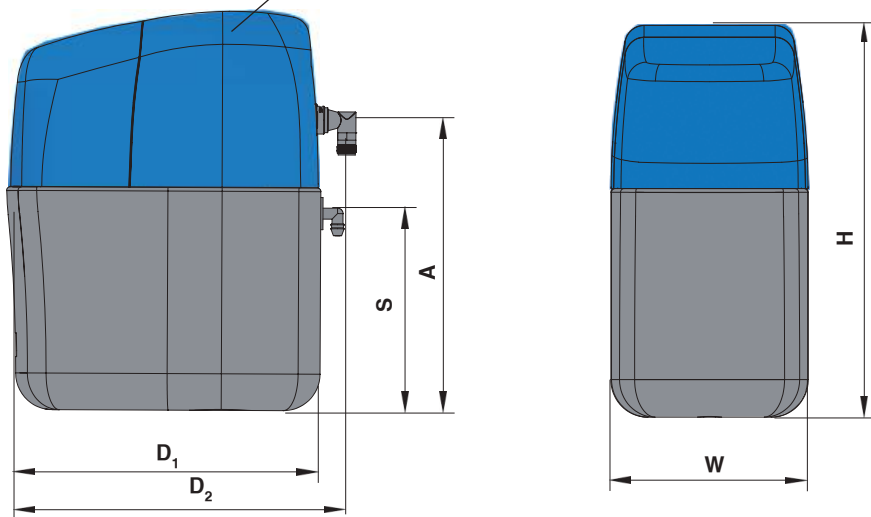



# Declaration of incorporation

EG Konformitätserklärung / Certificat de Conformité CE

The company **BWT water + more GmbH** declares that the product water softener with the following specifications:

<b>Trade name of product :</b>	<b>Type :</b>	<b>Model :</b>
• <b>BWT pro-soft</b>	<b>11</b>	<b>10 litres</b>

with a serial number higher than: see rating plate & technical specifications  
and with a production- and reference no.: see rating plate & technical specifications

have been designed, manufactured and assembled according to the following **EC Directives (guidelines)**:

**2006 / 95 / EC** Guideline for low voltage (LVD)

**2004 / 108 / EC** Guideline for electromagnetic compatibility (EMC)

**Note:** Do not perform any changes, extension and reconstruction work on the device which might impair safety without the approval of BWT water + more GmbH, otherwise this declaration loses its validity.

**Note:** Please ensure that all conditions of the installation preconditions are met!

**Manufacturer:** BWT UK Ltd., Coronation Road, Buckinghamshire, HP12, 3SUH

**Distribution:** BWT water + more GmbH, Walter-Simmer-Straße 4, A-5310 Mondsee, Tel. : + 43 (0) 6232 5011 - 0

Buckinghamshire, 21<sup>th</sup> November 2013  
Place, date / Lieu, date / Ort, Datum



Ian Threadgill  
General Manager Supply Chain

For You and Planet Blue.



# BWT – The Company

The Best Water Technology Group is Europe's leading water technology company with 2,800 employees and a vast network of partner companies, service staff, installers, planners, architects and hygiene experts. Our R&D teams apply state-of-the-art methods and use the latest processes and materials to create products that are both economical and green. One of the key objectives is to reduce the resource and energy consumption levels of our products, resulting in a reduction in CO<sub>2</sub> emissions.

Practically everywhere where water is involved, BWT's pioneering products have proved their worth millions of times over; where domestic water enters a building ('point of entry') and at its tapping point ('point of use'), for the treatment of seawater, drinking water, mineral water, ultrapure water for pharmaceuticals, water for swimming pools, heating and process water, boiler water, cooling water and water for air-conditioning systems. Our numerous innovations enable our customers to enjoy the highest levels of safety, hygiene and health in their daily use of water – the precious elixir of life. Among these are: SEPTRON®, the world's first Electrodeionisation module (EDI) with spiral winding, the MDA (manganese oxide activation) method for effective removal of manganese, AQA total bipolar technology for chemical-free limescale protection, SANISAL – the world's first regeneration salt for softening systems that also disinfects at the same time, and the revolutionary new Mg<sup>2+</sup> technology for better tasting filtered water, coffee and tea. BWT, with its unique, high-performance membranes for fuel cells and batteries, is setting the 21<sup>st</sup> century standard for the supply of clean energy.

BWT – For You and Planet Blue signifies our mission to take ecological, economic and social responsibility, and to provide our customers with the best products, systems, technologies and services in all areas of water treatment, while making a valuable contribution to the preservation of our blue planet's global resources.

Rev. 1.03 - EN/ © BWTUK Limited

## **BWT UK Limited**

BWT House,  
The Gateway Centre, Coronation Road  
High Wycombe, Buckinghamshire.  
HP12 3SU  
Phone: 01494 838 100  
Fax: 01494 838 101  
E-Mail: [waterandmore@bwt-uk.co.uk](mailto:waterandmore@bwt-uk.co.uk)

[www.bwt-uk.co.uk](http://www.bwt-uk.co.uk)

